

SPINAL CORD INJURY PATIENT HANDBOOK



Carolinan HealthCare System

INTRODUCTION	3
SECTION I	6
Spinal Cord Injury Facts	7
Spinal Cord Injury Research.....	11
SECTION II	12
Autonomic Dysreflexia	13
Bladder Management.....	18
Bowel Management	40
Medications.....	47
Pain Management	55
Nutrition	57
Respiratory System	64
Skin Care	75
SECTION III	85
Adaptive Equipment	86
Hazards and Safety Precautions	88
Mobile Technology.....	93
Upper and Lower Extremity Range of Motion.....	97
Driving.....	110
Recreation	128
SECTION IV	132
Sexuality for Men.....	133
Sexuality for Women	137
Wellness and Resilience	145
SECTION V	159
Financial and Community Resources.....	160
Emergency Preparedness.....	178
Home Modifications	186
Ramp Specifications	190

INTRODUCTION

As part of Carolinas HealthCare System, Carolinas Rehabilitation has been helping people recover from injury and illness for more than 60 years. Our goal is to restore each person to a life that is as full and rewarding as possible – and to get that person back home as quickly as possible. That is our goal for you, too.

This handbook is part of how we will help you reach that goal. It contains key information that will help you understand your condition and tells you how to best manage the medical and physical challenges posed by your spinal cord injury. This handbook will help you continue your recovery once you leave the hospital. The information in this handbook is specially selected for you. What you will read is based upon the type of injury you had, where it was located in your spine, and your needs after you have left the hospital.

Year after year, an outside research company has found that we return more people to their homes than most other rehabilitation hospitals in the South or anywhere else in the country. We attain these results by using an entire team of specialists to aid you during your recovery.

Our team of specialists is called a “care team.” You and your family are the most important members. Other members of your team include a physiatrist (a doctor who specializes in rehabilitation medicine), nurses, physical therapist, occupational therapist, social worker, and urology nurse. There are also nutritionists, vocational counselors, vocational evaluators, a chaplain, educational specialists, and others who will work with you if you need their services. Our team approach provides you with state-of-the-art care that is matched to your special needs.

About Carolinas Rehabilitation

Carolinas Rehabilitation is a not-for-profit rehabilitation hospital that was founded in 1950. It is a facility of Carolinas HealthCare System. With beds for 192 inpatients dealing with spinal cord injuries, strokes, brain injuries, amputations, bone injuries, cancer, and more, Carolinas Rehabilitation is one of the largest comprehensive rehabilitation centers in the Southeast. We also provide a long list of outpatient services to help patients continue their recovery after they have left the hospital. You may be scheduled for some of these services after you leave the hospital.

Carolinas Rehabilitation is also a training center for doctors specializing in rehabilitation medicine as well as many other rehabilitation specialists. Our staff conducts rehabilitation research of many kinds and is continuously looking for better and more effective ways to help our patients.

How to Use Your Spinal Cord Injury Handbook

Your level of recovery will depend largely on how hard you work in your therapies and your commitment to caring for yourself. To make sure you learn as much as possible, you should read this handbook carefully. The Handbook is designed to complement the Spinal Cord Injury Education class series. The class series is a one-hour educational class offered every afternoon from 3 to 4 p.m. Each class is taught by a member of the interdisciplinary team at Carolinas Rehabilitation. This team includes your occupational and physical therapists, recreational therapists, nutritionist, wheelchair seating specialist, among many others. Your family is welcome to join these classes, and questions from all are encouraged. There are 10 classes total over a two week period, and the classes are interactive so you can learn as much about your injury and recovery as possible. Bring your Handbook to your therapy sessions and education classes to reinforce what your therapists are teaching, and review your Handbook to reinforce what you are learning.

If something doesn't make sense or if you run across medical terminology you don't understand, ask about it. Your doctor, nurses, and therapists all understand how important it is that you learn everything you can. Questions are welcome. The quality of your future depends upon what you learn.

When you leave the hospital, it will be up to you to put everything you learned into practice. Refer to it when you encounter new or difficult situations; it is like having a therapist with you.

Finally, be sure to bring your handbook when you see your family doctor or visit the clinic. It can help your doctor understand more about how to handle your spinal cord injury – and it is a handy place to add new information. You should also bring it when you return to Carolinas Rehabilitation for a clinic visit or outpatient therapy.

A Final Thought

We want to wish you the best in your recovery, and we're honored that you chose Carolinas Rehabilitation to help with your recovery. We will do everything we can to make your stay here as successful as possible.

One

SECTION I

SPINAL CORD INJURY FACTS

Spinal Cord Injuries

A spinal cord injury is caused by trauma or disease to the spinal cord, most often resulting in paralysis (loss of strength), loss of sensation (feeling), and loss of control of bodily functions.

Currently, there are approximately 273,000 people in the United States who have spinal cord injury with 12,000 new injuries each year.

Since 2010, the average age at injury is 42.6 years of age, with 80.7 percent of injuries occurring in men. There has also been an increase in the number of persons over 60 who have spinal cord injuries.

Causes of Spinal Cord Injuries Since 2010

- 36.5% – Vehicular accidents
- 28.5% - Falls
- 14.3% - Violence
- 9.0% - Sports
- 11.4% - Other/unknown

Paralysis, or loss of muscle strength, is the initial source of medical problems in persons with spinal cord injuries. Secondary medical problems include demineralization of bone, degeneration of the circulatory system, kidney and bladder dysfunction, pneumonia, and pressure sores.

The average person who sustains a spinal cord injury can expect to be in rehab for three to four weeks and spend \$400,000 on medical care. 87.1 percent of all persons with SCI are discharged from rehab to their private home, usually returning to their residence before the injury. At the time of the injury, 57.1 percent of persons sustaining a SCI were employed. After one year, 11.8 percent of those with an SCI are employed, and after 10 years, 34.9 percent are employed.

(Information from the National Spinal Cord Injury Statistical Center, Birmingham, AL, www.nscisc.uab.edu/PublicDocuments/fact_figures_docs/Facts%202013.pdf)

The Normal Spinal Cord

Your brain is a lot like a computer for your body. It sends and receives messages from all parts of your body and handles all the complicated functions of your body. The spinal cord is the pathway traveled by the messages between the brain and other parts of your body.

The spinal cord is made up of many nerve fibers. The spinal cord is surrounded and protected by round bones called vertebrae. The vertebrae are stacked one on top of another like a chain, also called a backbone. The spinal nerves branch off the spinal cord between the vertebrae along the neck and back. These spinal nerves carry sensory and motor information. Sensory refers to your ability to feel, and motor refers to your ability to move. The sensory information goes from your arms and legs to your brain and the motor information goes from your brain to your arms and legs.

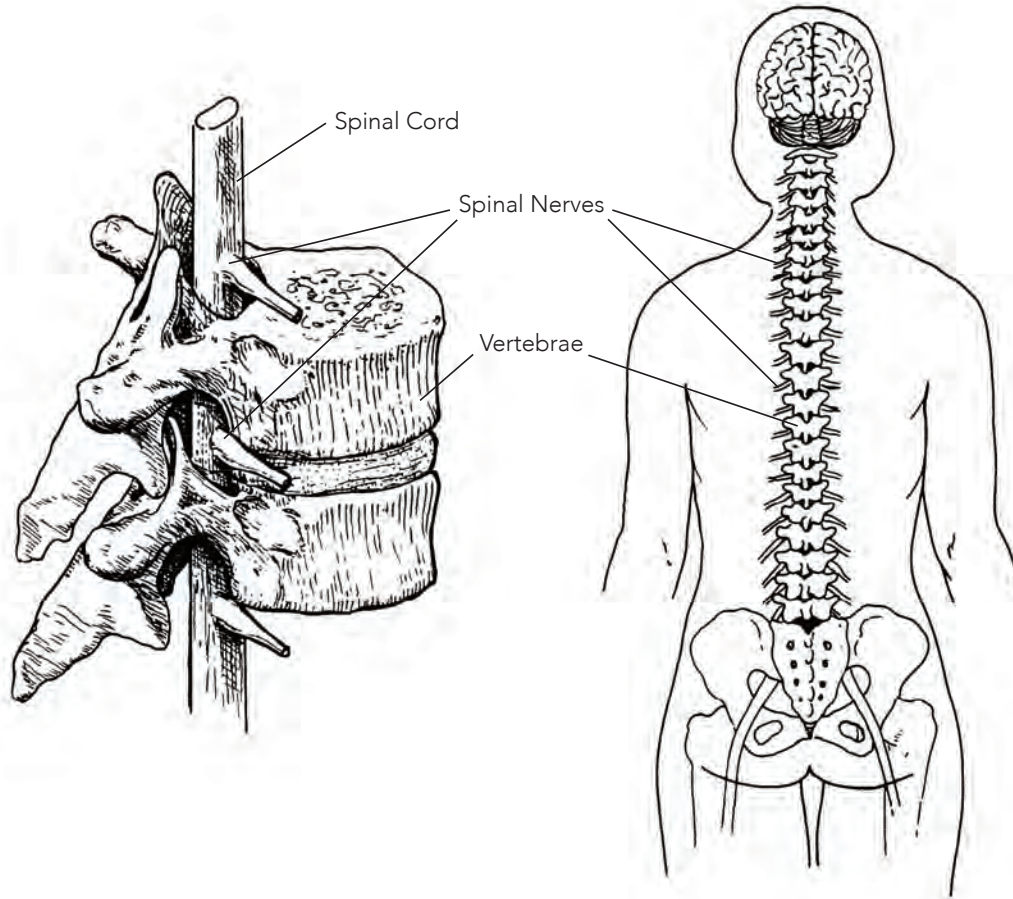

The Spinal Cord After an Injury

With a spinal cord injury, all the nerves above the injury keep working like they always have. Below the injury, feelings like hot, cold and pain can't get to the brain, and messages from the brain asking for movement can't get to the muscles. The closer the injury is to the brain the more of your body will have no feeling and the more muscle weakness you will experience. For example, someone with a T8 injury will typically have more feeling and movement than someone with a C5 injury. In addition to affecting movement and feeling, a spinal cord injury affects some body functions, such as bowel, bladder and sexual activities.

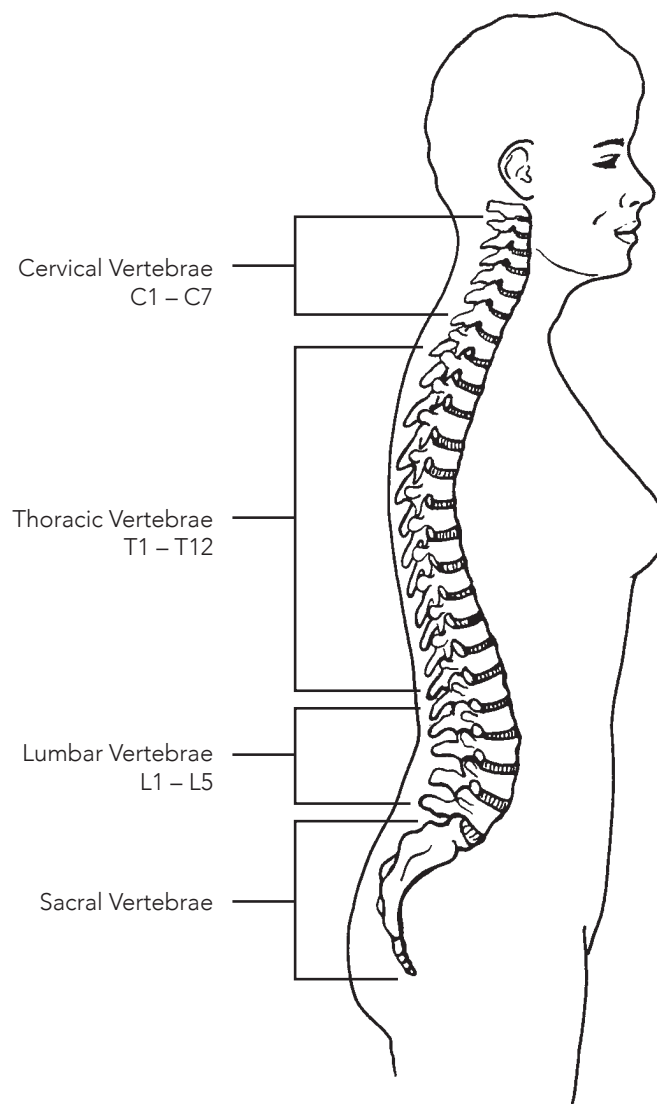

Types of Spinal Cord Injury

The spinal cord damage can be severe where no information (feeling or movement) is able to pass the area of damage in the spinal cord. In a less severe case, some messages are able to pass the damaged area. The amount and type of messages that can pass will depend on how many of the nerves are damaged in the spinal cord. Some people may have a lot of feeling, but little movement. Others may have some movement and very little feeling. Spinal cord injuries will be different from one person to another because of the different nerves that are damaged. Sometimes the spinal cord is only bruised or swollen. With time, the nerves may heal and begin to work again. We do not have any tests at this time to predict which nerves (if any) will begin to work after spinal cord injury.

We use a scale called ASIA (American Spinal Injury Association) Impairment Scale to determine the degree of damage to the spinal cord. Your doctor and therapists will test you to see which areas of your body have normal or impaired feeling and normal or impaired movement. This helps to determine how severe the damage was to the spinal cord and will be continually monitored for improvement.

ASIA Impairment Scale

- ASIA A: means there is no feeling or movement below the damaged area in the spinal cord
- ASIA B: feeling, but no muscle strength, is present below the damaged area
- ASIA C: weak muscle strength is present below the damaged area
- ASIA D: strong muscle function is present below the damaged area
- ASIA E: feeling and muscle function is normal below the damaged area of the spinal cord

SPINAL CORD INJURY RESEARCH

The physicians, nurses and clinicians at Carolinas HealthCare System are actively involved in several research studies related to spinal cord injury treatment. We encourage you to have your name added to our Spinal Cord Registry so we can contact you following your discharge if we become aware of a study or program we feel you would benefit from. Your nurse or therapist can contact our Research Department if you are interested.

Research studies are currently underway in many areas including:

- Medication Management
 - Heart Disease Prevention and Management
 - Pressure Ulcer Management
 - Hypothermia
- Functional Electrical Stimulation
- Cellular Therapy
- Depression
- Fertility
- Pain
- Spasticity
- Bowel and Bladder
- Respiratory (Ventilator weaning)

Before participating in any clinical trial it is important to educate yourself. You should discuss whether a study is appropriate for you with your physician. We also recommend you read the following:

- Experimental Treatments for Spinal Cord Injury: What You Should Know If You Are Considering Participation In A Clinical Trial 1-800-539-7309
- www.icord.org/ICCP/Experimental_treatment_for_SCI-full.pdf

You can get more information on current clinical trials from the following resources:

- Chapter 4 Paralysis Resource guide
www.nxtbook.com/nxtbooks/crf/paralysisresourceguide/
- ClinicalTrials.gov
- RehabTrials.org 973-243-6806
- [Center Watch.com](http://CenterWatch.com) 617-948-5100
- Spinal Cord Injury Information Network: Research Studies
www.spinalcord.uab.edu/show.sp?durki=21777

One

SECTION II

AUTONOMIC DYSREFLEXIA

Autonomic dysreflexia (ot-toe-NAWM-ick dis-re-flex-ee-ah) is an emergency situation and a complication that can be seen in almost anyone with a spinal cord injury above the thoracic level 6. It is important to be able to recognize this complication and know what causes it and how to treat it, as it can be life threatening.

What May I See And Feel?

Symptoms (you may not have all of them)	Why does this happen?
Severe pounding headache	High blood pressure
Seeing spots in front of your eyes	High blood pressure
Blurred vision	High blood pressure
Slow heart rate	Brain's response to high blood pressure
Goosebumps above level of SCI	Body's exaggerated response to continuous dilation of blood vessels
Sweating above level of SCI	Body's exaggerated response to continuous dilation of blood vessels
Flushing of skin above level of SCI	Body's exaggerated response to continuous dilation of blood vessels
Nasal stuffiness	Body's exaggerated response to continuous dilation of blood vessels

IMPORTANT: Uncontrolled high blood pressure is the dangerous part of autonomic dysreflexia, for it may be high enough to cause a stroke.

What to Do if You Have These Symptoms

1. **Sit up if you are lying down.** This will decrease your blood pressure.
2. **Find and remove the cause.** Autonomic dysreflexia usually will not go away until the cause of the problem has been corrected.
 - **Check for bladder problems first.** If you do not have a catheter in place, catheterize yourself. Empty your bladder slowly by lifting the draining end of your catheter. If you empty your bladder too fast, you may cause it to go into spasm, which can cause your blood pressure to go up again.
 - **Check for bowel problems next.** If your bladder is not the cause of the high blood pressure, check your bowel for stool. If there is stool in your rectum, you will need to remove it manually. Before removing the stool, you should apply numbing medicine to the anus and then wait five minutes for the medicine to work. This will prevent further stimulation to the area, which can cause your blood pressure to go up even more.
 - **If overheated,** place a cool damp cloth on your head, at your groin and armpits, and get to a cool place.
 - **Check for skin problems.** If neither your bowel nor your bladder seems to be the cause, remove your clothing and look for cuts, bruises, or ulcers on your body.
3. **Apply Nitroglycerin ointment to your skin above the level of injury, or take nifedipine if your physician has given you this medication.** This will lower your blood pressure while you are trying to find out why this has happened. Only certain patients who get autonomic dysreflexia frequently will be given this medication.
4. **GET HELP** if you can't find the cause. Call or go to the nearest hospital. Autonomic dysreflexia is an unusual problem, and not all health providers will know how to treat it.

A physician should be notified immediately, as this is a medical emergency.

What Causes It?

Autonomic dysreflexia is generally brought on by something that would have signaled pain or discomfort before your injury. Some possible causes are listed below, with the most common first.

1. A full or distended bladder (frequently caused by a plugged catheter)
2. Stool impaction (severe constipation)
3. Infections (bladder, etc.)
4. Medical tests and procedures
5. Pressure sores
6. Traumatic pain (severe cuts or broken bones)
7. Hot and cold temperatures
8. Sunburn
9. Tight clothes
10. Pressure on the testicles or penis
11. Severe menstrual cramps, labor (uterine contractions)
12. Stomach ulcers
13. Certain drugs

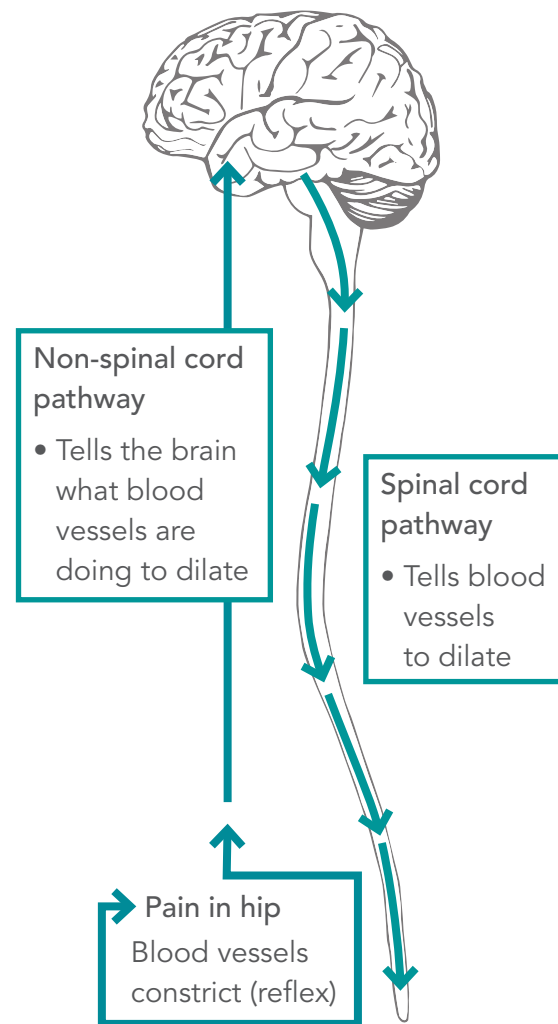

How Does It Happen?

The Body's Response to Pain: *Before SCI*

1. Blood vessels constrict by reflex activity and raise your blood pressure.
2. Nerves send messages up to the brain through your spinal cord, so you actually feel the pain.
3. Other nerves send messages up to the brain through automatic pathways other than the spinal cord to tell the brain what is happening to your blood vessels and blood pressure.
4. The brain then sends a message down through the spinal cord to dilate (open up) your blood vessels, which will lower your blood pressure again.

The Body's Response to Pain: *After SCI*

1. Blood vessels constrict by reflex activity and raise your blood pressure.
2. You will most likely not feel the pain, because the pain messages cannot pass through the injured spinal cord.
3. Other nerves send messages up to the brain through automatic pathways other than the spinal cord to tell the brain what is happening to your blood vessels and blood pressure.
4. If your injury is at or above T6 level, your brain cannot get the dilation message back down to the blood vessels below your injury. The reason for this is that the area from T6 to T10 of the spinal cord sends messages to most of the blood vessels in your body. Your blood pressure stays high because the shut-off valve to lower your blood pressure does not work.

IMPORTANT: Autonomic dysreflexia is like a vicious cycle that cannot be broken until you find the cause and remove it. This can be a life threatening emergency.

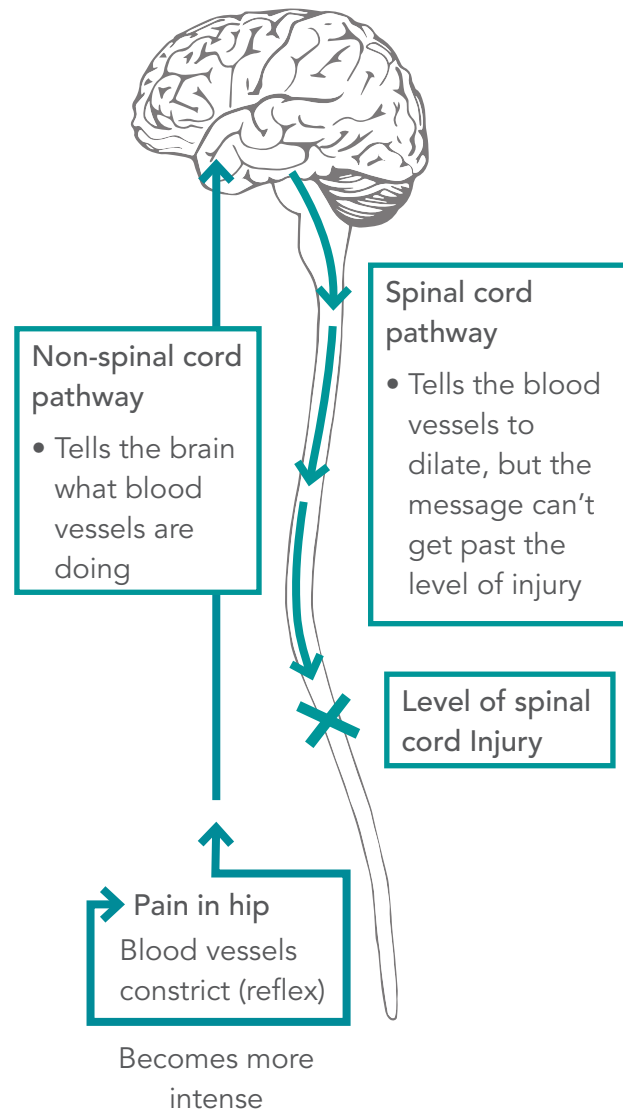

Can Autonomic Dysreflexia Be Prevented?

You can prevent these symptoms in many cases, but not always.

Since the most common causes of autonomic dysreflexia are a full or distended (bloated) bladder and impactions of the bowel, you can prevent this from happening by making sure:

1. Your bladder is emptied routinely.
2. Your catheter is draining well.
3. You have routine bowel movements.

If you have this problem more frequently, your doctors may put you on medication to prevent it.

REMEMBER: If you do develop autonomic dysreflexia, you will soon learn what causes it for you. Then you will be able to treat it quickly and effectively.

CARRY YOUR CARD! If you are at risk for autonomic dysreflexia, your nurse or therapist will give you a card. The card explains what autonomic dysreflexia is and how to treat it. Carry this in your wallet or purse at all times. Let people know you have this card and use it with medical staff to instruct them in Emergency Care. It may save your life!

BLADDER MANAGEMENT

Before your spinal cord injury, you probably did not pay much attention to your urinary system because urinating occurred so automatically. During the first few months after injury, you and certain members of the spinal cord injury team will be spending what seems like a great deal of time establishing and managing your bladder program. Eventually, your bladder program will become quick and routine.

In this chapter, we will explain:

1. The urinary system.
2. How the urinary system has changed since your SCI.
3. The reasons for bladder management.
4. How to recognize and avoid problems.

The Urinary System

The urinary system consists of the kidneys, the ureters (YURR-ut-airs), the bladder, and the urethra (yur-EETH-rah). Refer to the upcoming sections on male or female urinary systems for diagrams.

How Does My Urinary System Work?

The kidneys remove wastes and excess water from your blood stream and process them into urine. The urine then flows down small tubes called ureters to your bladder. The bladder is a muscular sac that stretches to hold urine until the body is ready to void (urinate). When voiding occurs, the bladder contracts and the sphincter (which is a circular muscle acting as a gate) opens. Urine then passes through the sphincter into a tube called the urethra and you urinate.

Kidney: Toxic wastes and excess water are filtered through the kidneys and processed into urine.

Ureter: Urine passes from the kidneys to the bladder through small tubes called ureters.

Bladder: The bladder is the body's storage tank for urine. It is a hollow sack made of thick muscle which stretches to fill and contracts (squeezes) to empty.

External Urethral Sphincter: The sphincters are muscles that control the outflow of urine.

Urethra: Urine passes from the bladder to outside of your body through the urethra.

Normal Urination

Urination is due to a finely balanced coordination of bladder and sphincter muscles. This coordination involves both voluntary and involuntary (or automatic) control by the nervous system. When the bladder becomes full, messages are sent to the lower level of the spinal cord in your pelvis. Messages are then sent through your spinal cord to your brain to let you know that your bladder is full. At this time you can decide to either urinate or hold the urine. This is the part under voluntary control. If you want to urinate, the brain will send messages down the spinal cord and back to the urinary system. The involuntary part involves the opening of the sphincter muscle, and bladder muscle contraction. This allows your bladder to keep urine pressures low.

How Is My Bladder Function Changed By Spinal Cord Injury?

Nerve impulses from the bladder can no longer get to and from the brain to let you sense that your bladder is full or to let you void. There are two general kinds of bladder dysfunction that can occur depending on your level of injury. Because there can be individual variations, you will probably have some tests to diagnose your particular bladder type.

These types of bladder dysfunctions are described next.

- **Upper motor neuron bladder (reflex or spastic bladder)**

In this condition, the bladder tends to hold smaller volumes of urine than before SCI. Just like your other muscles may have spasms and contract on their own, so can the bladder muscle. The result is that you may have frequent, small urinations without control. This bladder type is common in most spinal cord injuries above the sacral level. This type of urination generally happens with elevated bladder pressures and is a significant cause of urinary tract infections (UTIs).

- **Lower motor neuron bladder (flaccid bladder)**

In this condition, the bladder muscle has lost its ability to contract and can be easily stretched. Therefore, large volumes of urine can be held by the bladder at low pressure. Because the muscle cannot contract, urine leaves the bladder only when it is overfilled. The urine “spills over” out of your bladder into your urethra like a glass that is too full of water. The bladder type is common when SCI affects the sacral level of the cord (cauda equina injuries).

What Tests Are Done to Check My Bladder Function?

There are a number of tests that can evaluate the structure and function of the urinary system. You may have one or several of them.

What is an ultrasound?

An ultrasound, or sound waves (like sonar) are bounced off tissue surfaces, and an electronic picture is produced on a screen. Variations in the color of the image can detail the structures or anatomy and thus define problems.

What is an intravenous pyelogram (IVP)?

An IVP is done by injecting dye containing iodine into a vein. This is excreted by the kidneys and shows up in X-ray. This X-ray will show the size, shape, and working order of the kidneys, ureters, and bladder.

PLEASE NOTE: if you have ever had an allergic reaction to IVP dye, be sure to tell your physician.

Your bowel needs to be empty for this test, so do a good bowel program the evening before or the morning of the test. You may also have to refrain from eating and drinking the night before the test. The nursing staff will let you know if other preparation is necessary.

What is a renal scan?

The purpose of a renal (REE-null) scan is to assess the function and the blood supply of the kidneys. It is done by injecting a radioactive substance into a vein before X-rays are taken of the kidneys. The amount of radioactivity is extremely low.

What is a cystourethrogram (siss-toh-yurr-EETH-roh-gram)?

This is also called a cystogram, and is another X-ray study which shows the size and shape of the bladder. Dye is inserted through a catheter into the bladder, and this shows up on an X-ray. Among other things, this test shows if urine moves backward through the system from the bladder up to the kidneys. This condition is called reflux. Reflux is due to excess pressure in the bladder. This is one cause of kidney damage and needs to be detected early.

What is urodynamics (yurr-oh-die-NAMM-icks)?

A urodynamics evaluation consists of a series of studies that provide information about the mechanics of voiding. Tests which may be part of this urodynamics evaluation include a cystometrogram, a study of urine flow, a study of urethral pressures, and your response to medication that can affect voiding. These tests also give information on sphincter activity and urethral pressures, during bladder filling and emptying. This aids in planning the best bladder management program for you.

What is a cystometrogram (siss-toh-METT-roh-gram) (CMG)?

A CMG shows how your bladder reacts when it is filled with either carbon dioxide (CO₂) or water. This mimics the way it would usually react when filled with urine. A catheter is inserted for this test. A CMG helps determine if you have a UMN (Upper Motor Neuron) or LMN (Lower Motor Neuron) bladder type. The amount of pressure which builds in your bladder will also be measured by this test.

What is a cystoscopy (siss-TOSS-koh-pee)?

Cystoscopy involves the urologist looking at the inside of your urethra and bladder through a lighted, hollow, specialized catheter inserted through the urethra. This is used in diagnosing problems occurring inside the bladder.

What other laboratory tests are done?

There are a number of tests evaluating the blood and urine that show how your urinary system is functioning:

- **Creatinine (kree-AT-en-een) clearance:** This test involves collecting all of your urine for a 24-hour period. It is an important indicator of kidney function.
- **Urine cultures:** In this test, a sterile urine specimen is sent to the laboratory to look for bacteria. When a sensitivity is also ordered, specific antibiotics that kill these bacteria can be determined.
- **Urinalysis:** Urine is analyzed for a number of different chemical and cellular products.

How Do I Empty My Bladder After SCI?

If you have an incomplete injury, you may eventually regain all or some voluntary control of your bladder.

If you have a complete injury, one or a combination of the following bladder emptying techniques will become part of your bladder management program.

Catheterization

A catheter is a small rubber or plastic tube inserted into the bladder to drain urine. If this is done several times a day, we refer to the process as an intermittent catheterization program, or ICP. ICP is generally done by the nursing staff on all SCI persons in the first stages after injury. It may also be continued at home.

A catheter that is left in the bladder is an indwelling catheter. It is often referred to simply as a “foley.”

Another less common type of catheter is the suprapubic catheter. This type is placed through the abdomen into the bladder. The type of catheter used by you depends on many factors and will be discussed with you by your doctor or nurse. This type of catheter, if it is appropriate for you, is typically placed after you leave rehabilitation.

Stimulated voiding

Sometimes the bladder can be mechanically stimulated to empty. Just as a spastic muscle may move when tapped or brushed, so may an Upper Motor Neuron bladder. We call this “tapping.” The tapping is done on your abdomen over your bladder. A Lower Motor Neuron bladder may empty with firm pressure over the bladder called crede (creh-DAY), or during straining or bending forward.

Spontaneous voiding

Some Upper Motor Neuron Bladder muscles spontaneously contract. For those who have bladders that trigger on their own, or who have had a sphincterotomy (SFINK-turr-AH-tom-ee; surgery to open the bladder “gate”), wearing an external collecting device will keep you dry. There are many different types of catheters, and your SCI team will work with you to find the best method.

What Are My Goals In Managing My Bladder?

1. To have bladder volumes below 500 cc.
2. To have low bladder pressures.
3. To avoid urinary tract infections.
4. To keep your skin dry.

How Are Bladder Volumes Kept Low?

Bladder volumes are kept low by:

1. Monitoring your fluid intake.
2. Routinely emptying your bladder.

ICP

If you are on an intermittent catheterization program, the amount of urine that collects in your bladder between catheterizations needs to be 500 cc or less. To assist with this, you may be asked to limit your fluid intake to a certain amount per day, as discussed with your doctor.

With four to six carefully timed catheterizations throughout the day, your bladder should not get too full. When you drink more than your schedule allows or if you do not catheterize yourself on time, you run the risk of exceeding the 500 cc bladder limit.

IMPORTANT NOTE: More than 500 cc in your bladder will over-stretch (overdistend) your bladder muscle and make you prone to infection or reflux. (See the section in this chapter, "How Can I Avoid Infection?" on the next page)

Foley/suprapubic catheter

These catheters are always draining urine, so your bladder does not fill at all. In this case, you need to drink as much fluid as you can to flush the normal mineral deposits out of your urinary system. Foley catheters and suprapubic catheters should always be taped. Male catheters should be taped to the pubic area.

Spontaneous/stimulated voiding

If you are using these methods of voiding, you will need to carefully balance your fluid intake. Since a certain volume of urine will trigger an Upper Motor Neuron bladder to empty, you may want to know what this volume is so that you can time yourself to get to an accessible bathroom to empty your bladder. By knowing at what volume your bladder will trigger and by watching your fluid intake (usually 125 cc per hour), you may be able to establish a routine time for bladder emptying.

How Are Bladder Pressures Kept Low?

In some bladders, there is a buildup of very high pressures before the bladder empties. These high pressures can cause urine to “back up” or reflux into the kidneys, causing damage. High pressures can be caused by:

1. Irritable Bladder

Your CMG or urodynamics study will measure and record the pressure and volume of your bladder.

2. Dyssynergia (DISS-inn-URR-jah)

This happens when the bladder contracts and the sphincter will not open. It's similar to trying to press the air out of an air mattress with the plug closed. Autonomic Dysreflexia can also occur with dyssynergia (see previous chapter in this book called “Autonomic Dysreflexia” - dyssynergia can be treated by either the use of medication to relax the sphincter or by surgery to open it if you are using a condom catheter).

3. Overfilling the bladder

To keep pressures low, keep your volumes below 500cc and treat dyssynergia if it occurs.

Reflux can damage your kidneys without your knowledge. This is a silent problem. Therefore, regular kidney examinations will detect the problem early. If this problem develops, your doctor will recommend a change in your bladder management.

How Can I Avoid Infections?

1. Maintain regulated fluid intake to “wash out” bacteria, to limit kidney stone formation, and keep urine clear/yellow in appearance.
2. Empty your bladder routinely and prevent overdistension. More than 500cc can weaken your bladder muscle in two ways. First, the muscle cells cannot fight off infection as well. Second, the muscle cannot contract as tightly and leaves behind a pool of urine in which bacteria can grow after you urinate.
3. While in the hospital, make sure you or your nurse uses a sterile technique for your catheterizations.

How Do I Keep My Skin Dry?

The best way to keep skin dry is to carefully follow your bladder management program.

1. Routinely empty your bladder by the method that works best for you.
2. Watch your fluid intake.
3. Avoid infections. Infections may make your bladder irritable, which can cause frequent incontinence or leakage around foley or suprapubic catheters.
4. If you do have an incontinent episode, change your clothes as soon as they get wet.
5. Examine your skin/pressure points daily.

SECTION II

Problem Solving

What If I get an Infection?

People with SCI are at risk for infection because mechanical methods are needed to empty the bladder. Infections are caused by bacterial growth. Three sites of infection common to SCI are the kidneys, bladder, and testicles (for males).

A kidney infection is called pyelonephritis (PIE-ell-low-neff-RIGHT-iss), a bladder infection is called cystitis (siss-TIETiss), and an infection involving the testicles is called epididymitis (epp-eh-DID-ee-MIGHT-uss).

The table below will help you understand these infections.

Type Of Infection	Signs & Symptoms	Diagnostic Tests	Treatment	Other Considerations
Kidney (pyelonephritis)	Chills, Fever, Flank Pain, Hematuria (bloody urine), Urinary Frequency, Cloudy, thick urine, Foul smelling urine, Sediment, Burning upon urination, Increased spasticity, Autonomic dysreflexia	Urinalysis Culture & sensitivity (C&S)	Increased fluid intake Antibiotics Foley catheter possible	Re-evaluate bladder management
Bladder (cystitis)	Same as kidney, although you may not have a fever & chills	Urinalysis Culture & sensitivity (C&S)	Increased fluid intake Antibiotics Usually not necessary to insert foley	Chronic attacks require re-evaluation of bladder management via Urodynamic Testing Cystoscope
Testicles (males) (epididymitis)	Swollen, warm scrotum Testicle pain Chills, fever Penile discharge	Ultrasound Nuclear scan of testicles	Antibiotics	Re-evaluate bladder management program Can also be sexually transmitted

SECTION II

What happens if I have kidney damage or kidney failure?

Kidney failure is a complex combination of conditions. Basically, it means your kidneys do not function properly. Infections, stones, or reflux can damage your kidneys. The SCI staff will check your kidney function by blood and urine tests as well as X-rays.

What about autonomic dysreflexia?

If your SCI is at the sixth thoracic level (T6) or above, you may develop autonomic dysreflexia. It is important that you read the previous chapter in this manual on autonomic dysreflexia. You will need to know the symptoms and how to take care of this condition immediately. This can be a serious and life-threatening problem!

What are urinary stones?

Stones can develop in the kidney, ureters, or bladder. They are collections of mineral deposits and can develop because of infection, high calcium levels, or an increase of other chemicals. They usually are small enough to pass through the urinary system and appear in the urine as sediment that looks like sand.

If they are large, they may block the urinary system and could damage your kidneys.

Stones may develop without your realizing it, so the SCI staff will probably evaluate your urinary system yearly. The table below will help you understand urinary stones.

Signs & Symptoms	Diagnostic Tests	Treatment	Other Considerations
Excruciating pain in lower back or lower abdomen, which may radiate to groin (for those who have sensation) Nausea Vomiting Anxiety, because you may not know why you are uncomfortable Frequent Infections Bloody Urine	Blood Specimen Urinalysis IVP Cystoscopy	Care is individualized depending on stone, but may include increased fluids, straining urine, and, if you need it, medication or surgery	Re-evaluate bladder management

Important Steps For Prevention of Kidney and Bladder Problems

1. Drink lots of fluids as recommended by your doctor. If you are performing intermittent catheterization you need to consistently keep volumes less than 500cc.
2. Take medicines according to the instructions of your doctor.
3. Check your bag often to be sure your bladder is draining properly.
4. Remember to get regular checkups to be sure your kidneys are in good condition, because problems can occur even when you don't feel sick.
5. You should drink:
 - water
 - tea
 - coffee
 - cranberry juice
 - apple juice
6. You should avoid excessive amounts of :
 - orange juice and oranges
 - grapefruit juice and grapefruit
 - milk
 - alcoholic beverages
 - ice cream
 - carbonated beverages
 - cheese
7. If you have signs of urinary infection, always check first to see that your bladder is emptying, then drink even more liquids to help flush your system. If the signs continue, see your doctor immediately. Common signs of infection are:
 - cloudy urine
 - dark urine
 - bloody urine
 - urine which has a strong odor
 - chills and fever, with changes in urine
 - increased muscle spasm
8. If you get a fever, think first that you may have a urinary tract infection. Call your doctor if it persists.
9. Follow these steps for urinary care and any others given by your doctor.

CATHETERIZATION INFORMATION FOR MALE PATIENTS

The Male Urinary System

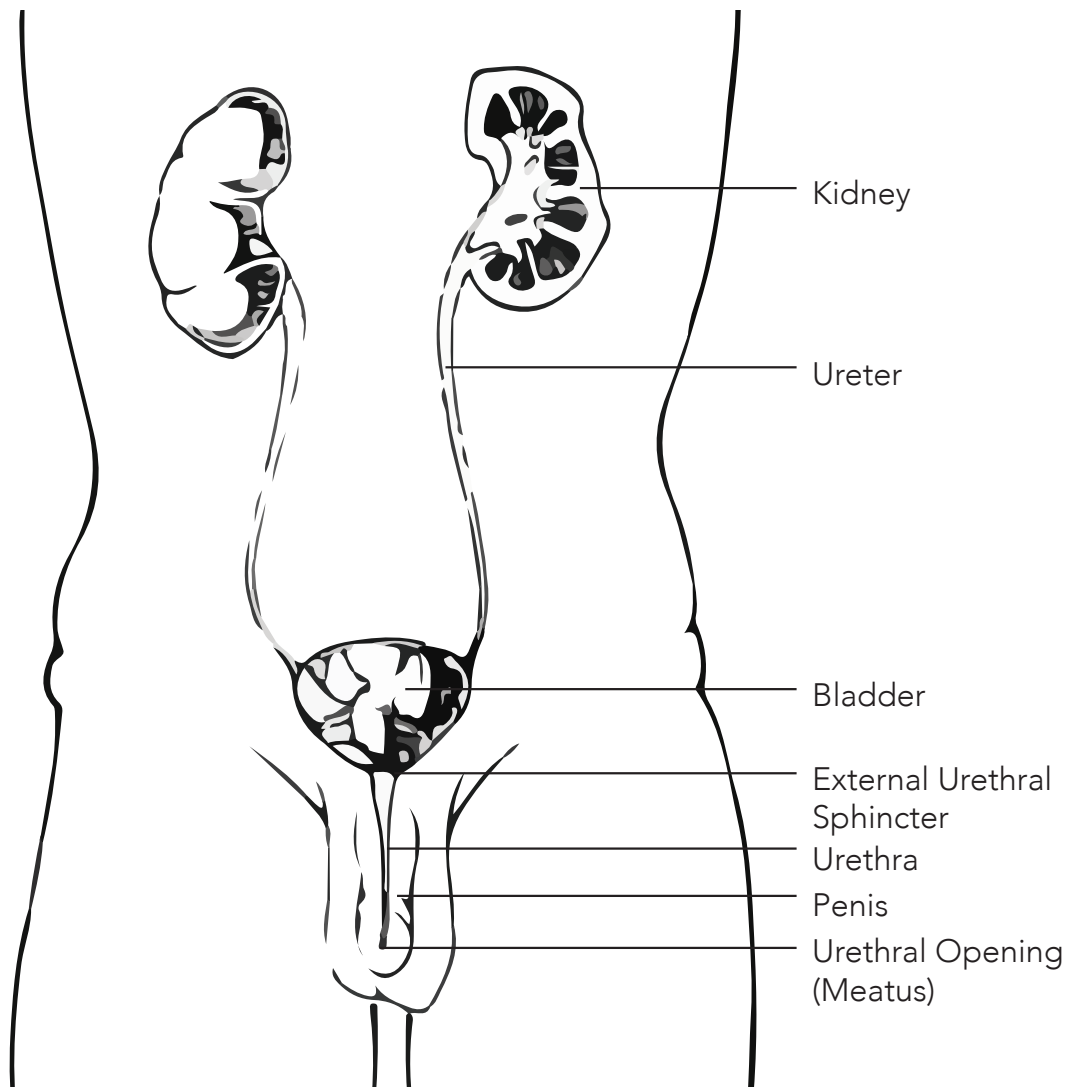

SECTION II

Male Self-catheterization Procedure – Clean Technique

Materials - Place these within easy reach.

1. Catheter – 14 Fr., may be kept in clean, dry plastic, bag, jar, or towel
2. Clean soapy washcloth
3. Towel
4. Lubrafax or K-Y Jelly (not Vaseline)
5. Container to drain urine in

Procedure

You can catheterize in your wheelchair, on a toilet, in bed or in the bathtub. Choose a place that is comfortable and easy for you and/or your helper.

1. Wash hands in soapy water.
2. Get in position to do catheterization.
3. Pull foreskin back as far as possible so you see the head of your penis. Hold penis up and clean head of penis with soapy washcloth.
4. Open Lubrafax or K-Y Jelly and place large amount on tip and length of catheter. Replace cap to keep lubricant clean.
5. With one hand, hold penis straight up.
6. With your other hand, pick up catheter and insert it carefully into the opening at the end of the penis (meatus). The catheter may come to an area where it stops. This is a muscle tightness; wait a moment and it will relax. Continue inserting catheter until urine comes out, then push in about one more inch.
7. Lower penis so catheter will drain into container. Empty all urine from bladder.



SECTION II

- To make sure the bladder is empty, push on your lower stomach below your belly button. Pull the catheter out slowly – if more urine comes out, stop. Let all urine drain out.
- Pinch off tip of catheter just before catheter tip comes out so you will not soil yourself.
- Wash catheter with soap and water, rinse well, store in clean, dry place (in a folded clean towel, baggie, or jar). Germs grow best on damp surfaces, so the catheter needs to dry before storing.

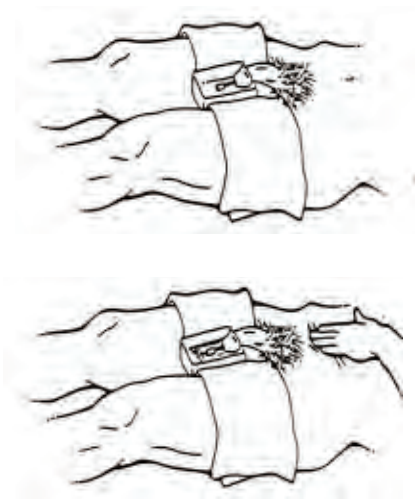

Applying a condom catheter

Materials

- Condom Catheter
- Elasticon tape
- Latex tubing (long enough to reach from a leg bag to the condom)
- Leg bag or bed bag
- Warm Water
- Soap
- Washcloth
- Towel

Procedure

- Wash your hands.
- Remove the tubing and connector from the condom you are wearing.
- Remove and discard the condom you are wearing.
- Clean your penis with soap and water. Dry well. Inspect your penis for any irritation.
- Roll the condom over the shaft of the penis. Make sure there is a space left between the end of the penis and the end of the condom.
- Hold hand over shaft of penis once condom is in place to help condom adhere to skin.
- Connect the condom to the tubing, as shown above.
- Wash your hands.

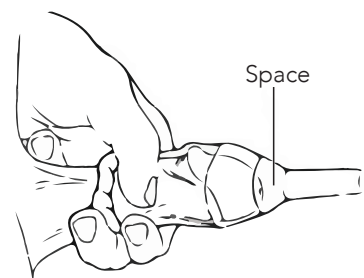
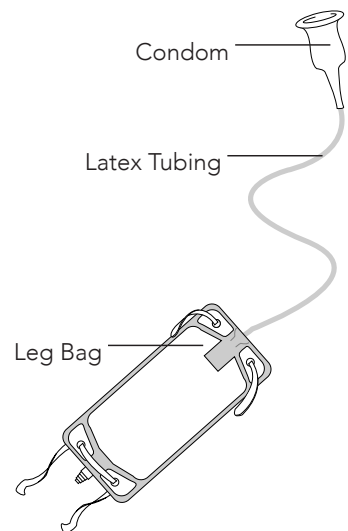

SECTION II

Cleaning urinary drainage equipment at home

Supplies

1. Soap and Water.
2. Soaking Solution: 1 oz. of bleach to 1 gallon of water OR 2 ½ oz. of Lysol® to 1 gallon of water. (Mix enough solution to cover and soak all urinary drainage equipment.)
3. Basin (large enough to soak equipment.)
4. Small funnel or irrigation tip syringe.
5. Hanger for drying.

Procedure

1. Remove external condom catheter.
2. Wash penis, groin and thighs well with soap and water.
3. Replace with new condom catheter, connecting tube, and leg bag or bedside drainage.
4. Wash all equipment with soap and water. (Leg bag, bedside drainage bag, connecting tubing and pieces of tubing used to make condom catheters.)
5. Place equipment in soaking solution, filling the inside of tubing, bedside bags and leg bags. Cover completely with solution and allow to soak 40 – 60 minutes. (A small funnel or irrigation tip syringe can be used to fill the inside of the bags.)
6. Rinse inside and outside of all equipment well after soaking. (A rash could result if not rinsed properly.)
7. Hang to dry as shown below.

Sediment in the urine may collect in tubing and connectors. If they are allowed to build up, it is harder for your urine to drain and you could get a urinary tract infection. Check your tubing and connectors every two to three days. If you see mineral buildup after regular cleaning, soak the tubing and connector in vinegar for six to eight hours. If this does not remove the buildup, the tubing or connector should be replaced.

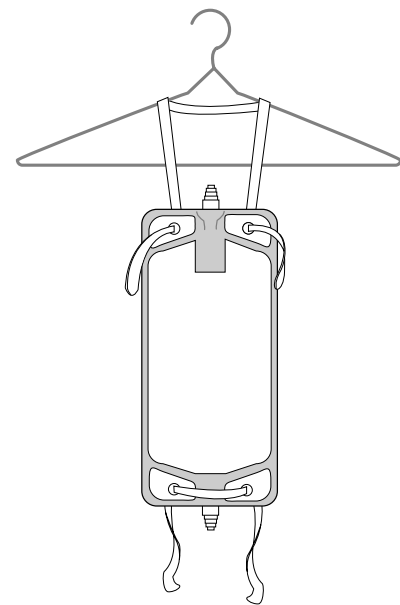

CATHETERIZATION INFORMATION FOR FEMALE PATIENTS

The Female Urinary System

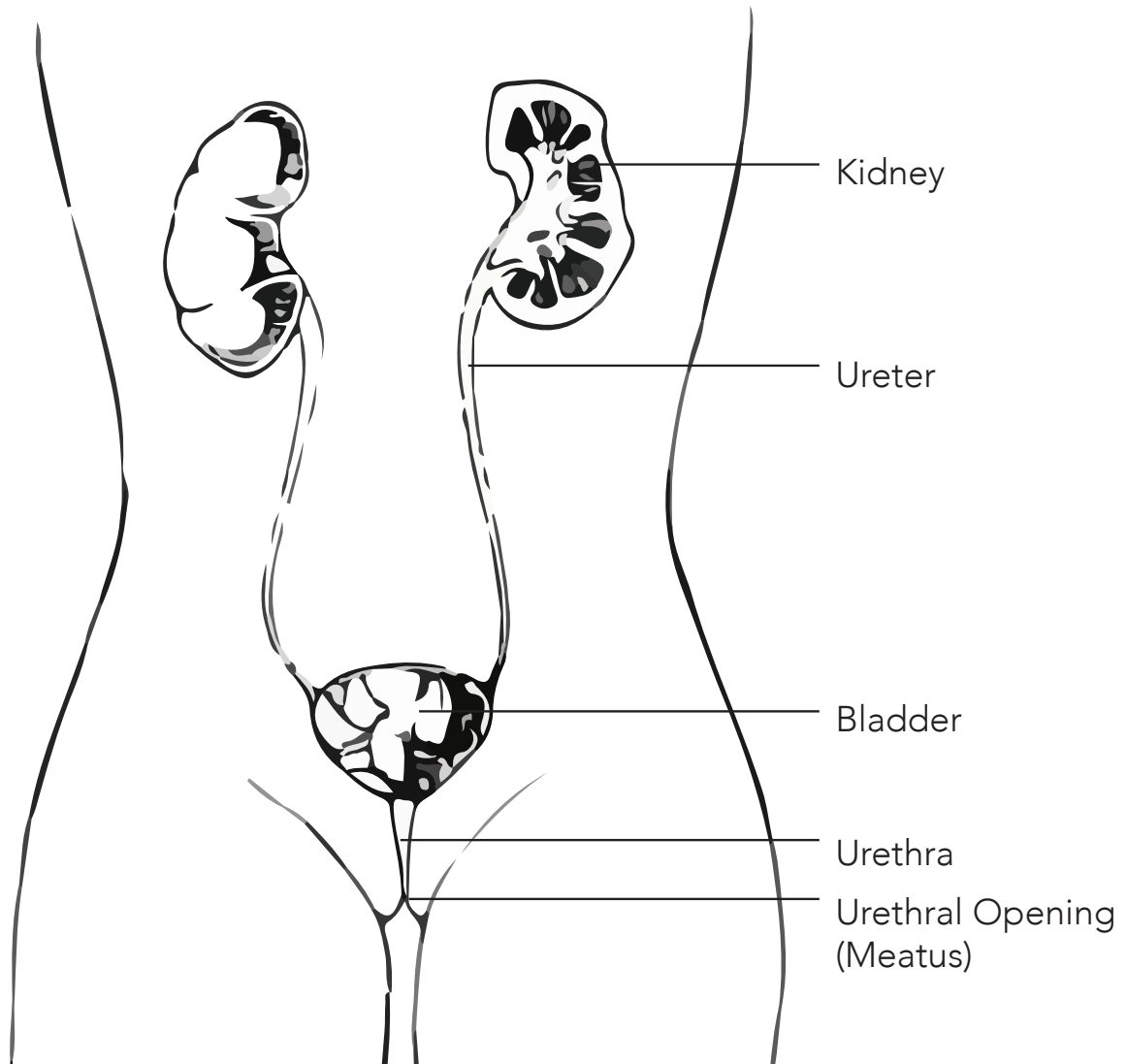

SECTION II

Female Self-Catheterization Procedure – Clean Technique

Materials

Place these within easy reach.

1. Catheter – 14 Fr. May be kept in clean, dry plastic bag, jar, or towel
2. Clean soapy washcloth
3. Towel
4. Container to drain urine in

Procedure

You will probably need to do your catheterization in bed while you are learning and may need pillows and a mirror. After you are more comfortable with the procedure, you can sit on a commode, in your wheelchair, in a bathtub or in bed to do your catheterization.

1. Wash hands with a soapy washcloth.
2. Get in position you need to be into most easily reach your bottom to do catheterization.
3. Hold folds of skin (labia) apart with your fingers so you can see or feel opening (meatus) to bladder. It feels like a small dimple just above the birth canal (vagina).
4. While still holding the skin back, wash with washcloth the opening to the bladder (meatus).
5. While still holding the skin open with one hand, pick up the catheter with the other hand.

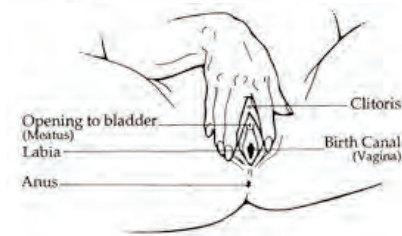

SECTION II

6. Insert the catheter into the opening (meatus) until urine comes out, then push the catheter in about 1 more inch.
7. Hold the catheter in place to keep it from slipping out. Empty all urine from bladder.
8. Push on lower stomach to ensure emptying. Pull catheter out slowly, about an inch – if more urine starts to come out – stop. Let all urine drain out of bladder.
9. Pinch off tip of catheter just before catheter tip comes out so you will not soil yourself.
10. Wash catheter with soap and water. Rinse well. Store in clean, dry place (in a folded clean towel, baggie, or jar). Germs grow best on damp surfaces. Catheter needs to dry before storing.



Urology Terms

Bladder: A balloon-like organ which holds urine.

Catheter: Soft rubber tube put into bladder to empty urine.

Catheterize: To pass catheter into bladder to drain bladder of urine.

Continence: Ability to control urine or stool.

Crede`: Applying pressure to the lower abdomen, right above the pubic bone, with hands. Press down to cause pressure on the bladder to empty the bladder.

Cystogram: A bladder X-ray in which dye is put into the bladder through a catheter. X-rays are taken to see the bladder shape and urinary outlet.

Cystometrogram: A test to check bladder pressure, sensation and muscle ability of the bladder. Air is put into the bladder shape and urinary outlet.

Cystoscopy: A surgical procedure. This may be done with the patient awake, and no incision is made. The urologist (kidney doctor) looks into the patient's bladder with a metal catheter. This may be done because the patient may have had a catheter (tube) in the bladder, which can cause small stones. These stones can be washed out during cystoscopy.

Diverticulum: Abnormal pouching of a tube such as in the tube from the bladder to the outside (urethra).

Erection: Stiffening of the penis.

External Urine Collector/Condom Catheter: Something a man can wear on his penis to collect urine when he is unable to control it. It is usually connected to a bag.

Foreskin: Loose skin some men have over the end of the penis.

Glans: Head of penis.

Incontinence: Not being able to control urine or stool.

Intermittent Catheterization Program (I.C.P.): Being catheterized every four, six, or eight hours to drain bladder of all urine.

I.V.P.: An X-ray in which dye is injected into the vein and X-rays are made of the kidneys. This is done to check the kidneys.

Kidneys: Two bean shaped organs in lower sides of back that make urine.

K.U.B.: A plain X-ray to look for stones in the bladder or kidneys.

Labia: Folds of skin around the vagina (birth canal).

SECTION II

Meatus: Opening to bladder.

Penis: Male sex organ.

Residual Urine: The amount of urine left in the bladder after urinating (passing your water). Catheterization should be done within ten minutes of urination to obtain a true residual.

Tapping: Thumping with fingers over bladder. This is used to stimulate bladder contractions in spinal cord patients.

U.P.P.: A test on the urethra (passage from bladder to the outside) to check the pressure that helps control urine.

Urethra: Tube from the bladder that urine passes through when you urinate.

Urinate: Void, passing water, making water.

Vagina: Birth canal.

BOWEL MANAGEMENT

How the Bowels Work

The bowels, or large intestines, are part of a long tube called the digestive tract which extends from your mouth to your anus. This tube digests food and turns it into fuel for your body. Some parts of the food are not digested. These solid waste products are stored in the bowel until they are expelled from the body as “stool” or “feces.”

The walls of the bowel are made of muscles which contract and relax automatically, pushing the stool down and out. The rectum is the lowest section of the bowel, where the stool collects until you are ready to move your bowels (go to the bathroom). The anus is the opening where the stool comes out. It has a donut-shaped muscle called the rectal sphincter (SFINK-ter) which, as a young child, you learn to tighten and relax in order to control your bowel movements.

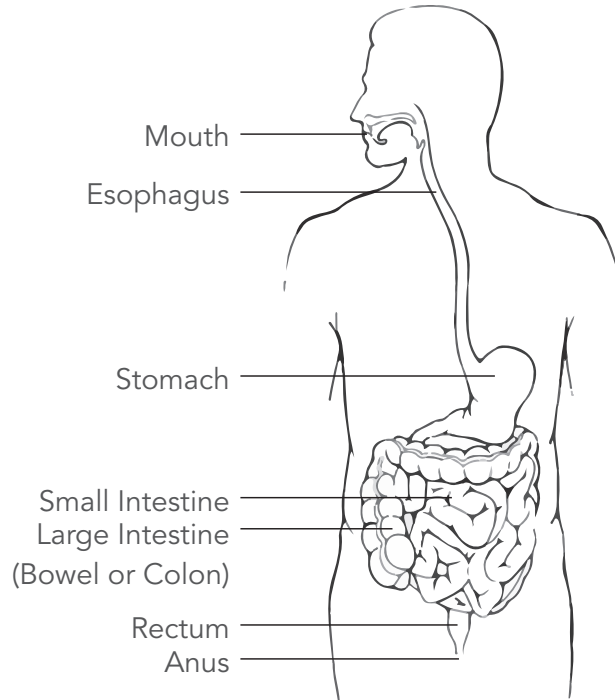

How the Bowels Move

The process of having a bowel movement is normally controlled partly by automatic reflexes and partly by voluntary muscles. Automatic wave-like movements of the bowel wall (called peristalsis) move the stool down toward the rectum at regular intervals. When some stool has collected in the rectum, you feel the need to go to the bathroom. Once on the toilet, you voluntarily relax the sphincter, push down with your abdominal muscles, and the stool comes out.

How SCI Affects the Bowels

After SCI, part or all of your voluntary control over your bowels may be lost. The sensation in your rectum may be impaired and you may not know when the stool is there. Even if you have sensation, you may not be able to control your sphincter, so you cannot hold in the stool, or let it out when you want to. You may be unable to push down with your abdominal muscles, making it harder to empty your bowels.

If your injury is above T12, you will probably have a “spastic” bowel. The sphincter functions correctly because the reflex is intact. But the awareness of the urge to empty your bowels is impaired, so you may have intermittent incontinence.

If your injury is below a T12, you will probably have a “flaccid” bowel. The sphincter will be relaxed and anal stimulation will have no effect. Peristalsis will move the stool down to the rectum, but it may not be strong enough to empty the bowel. You may not have awareness of the urge to empty your bowels. The stool may need to be removed manually at regular intervals to prevent incontinence.

The Importance of Your Bowel Program

A bowel program is simply a plan for emptying your bowels at the same time every day (or every other day) to prevent bowel problems and maintain control over your bowel movements.

A regular bowel program will help you avoid two common bowel problems of people with SCI: incontinence and impaction.

Incontinence is having a bowel movement when you do not want one. To prevent incontinence, you will empty the bowels at a regular time every day or two. This trains the bowels so that in most cases they will move only at the desired times.

An **impaction** is a mass of stool which gets stuck in the bowel and cannot be expelled by ordinary methods. This can happen if you allow the stool to stay too long in the rectum. The mass of stool becomes bigger and harder until it will not come out. This can make you seriously ill.

Common Bowel Problems

Constipation

Constipation is difficulty moving your bowels because of a hard, dry stool. It can cause many problems, such as muscle spasms, headaches, trouble sleeping, grouchiness, poor appetite, nausea, vomiting, hemorrhoids, or even dysreflexia.

If allowed to persist, constipation can become impaction, in which a hard mass of stool gets stuck in the bowel and cannot be removed by usual methods.

Measures to prevent or treat constipation:

- Drink adequate fluids and eat a well-balanced diet with plenty of fiber (whole grains, fruits and vegetables have the most fiber).
- Avoid or limit foods which tend to “bind” the bowels, such as apples, cheese, popcorn, and refined grains such as white rice or white bread.
- Follow a regular bowel program and make sure your bowels empty as completely as possible. Take stool softeners as prescribed by your doctor if needed.
- Be aware of how often your bowels move, and do not allow more than 2 days to go by without a movement. Try to stimulate your bowels to move, and if you cannot, tell your doctor. A laxative or enema may be prescribed.

Diarrhea

Loose, watery, frequent or explosive stools are called diarrhea. There are many causes, ranging from stress to an intestinal infection. Occasional mild diarrhea is usually caused by changes in your diet or fluid intake.

Measures to treat a diarrhea stool:

- Stop taking any stool softeners or laxatives you usually take until diarrhea stops. Cut down on fruit and fruit juices. Cut out all alcoholic beverages and caffeine until your stool is back to normal.
- Eat cheese, popcorn, rice or apples, which may help “bind” the stool.
- Drink plenty of fluids to replace the water lost through the stool.
- If diarrhea persists for more than 24 hours, notify your doctor. You can become seriously dehydrated (dried out) and lose vital substances with prolonged diarrhea.

Diarrhea or impaction?

A scant, watery stool can sometimes indicate impaction, as some loose stool leaks around the hardened mass of stool in the bowel. This can generally be distinguished from diarrhea by the relatively small amount. If you have “diarrhea” after not being able to move your bowels for a while, suspect impaction and notify your doctor. This condition requires medical treatment.

Hemorrhoids

Hemorrhoids are swollen blood vessels surrounding the anus. You may or may not be able to see them, depending on whether they are inside or outside the sphincter. Hemorrhoids are usually caused by hard stool irritating the anus, or by rough handling of the delicate anal tissue.

If you do not have feeling in your anal area, the first sign of a hemorrhoid may be bright red blood in your stool or in the toilet. If you or your helper notices a swelling, or a bloody stool, you should take measures to reduce the irritation and to prevent further damage.

Measures to prevent or reduce hemorrhoids:

- Keep the stool soft by taking plenty of fluids and high fiber foods and using a stool softener or laxative if prescribed by your doctor.
- Use plenty of lubricant during your bowel program and handle the anal area very gently. Keep fingernails trim and smooth.
- If you do have hemorrhoids, ask your doctor or nurse about using one of the over-the-counter ointments available at the pharmacy.
- If there is a lot of bleeding, tell your doctor. You may need medical treatment.

Bowel Program Timing

Timing is very important. The best time to do a bowel program is one half hour after a large meal. Eating causes the bowel to become more active, with increased peristalsis and often an urge to move the bowels. This called the gastro-colic reflex.

If your injury is Lower Motor Neuron, (generally, in the lower part of the spine) you will need to check your bowel after every meal. This will avoid accidents and clear the rectum so that the stool will keep moving down and out. Some people also do a bowel check before bedtime.

If your injury is Upper Motor Neuron, (generally, in the upper part of the spine) you will probably only need to do your program once a day, or once every other day. Whether to do your bowel program in the morning or evening is a decision you will make based on several factors:

- Did you have a regular time for bowel movements before your injury? Try to maintain that schedule if you can.
- What is your current school or work schedule? The bowel program should be scheduled to accommodate your other activities.
- Do you need assistance with the program? You will need to schedule it when assistance is available.
- How long does your bowel program usually take? It can be anywhere from five minutes to over an hour. Avoid rushing to prevent accidents.

Once you establish a good time, do your program at the same time (within ½ hour) every day. It may take up to several weeks to achieve regularity; once the program is well-established, you should not have bowel movements at other times. If you find after a trial period it is not working, or if you want to change because your schedule changes, it can be done, but it may take a while to make the transition. You should expect and provide for possible accidents until the new schedule is well established. Remember, even if you have an accident at another time during the day, it is important to continue to do your bowel program at your regular time.

While you are in the hospital, you will be given instructions on how to do your bowel program or how to instruct a helper to do it. Be sure to change the instruction if the program changes.

SECTION II

How to Do Your Bowel Program

Equipment needed:

1. Toilet tissue
2. Water-soluble lubricant
3. Suppository (if needed)
4. Adaptive equipment (if needed)
5. Protective sheet (or plastic bag) if performing in bed
6. Rubber gloves (lightweight kitchen gloves can be washed and reused)
7. Air spray

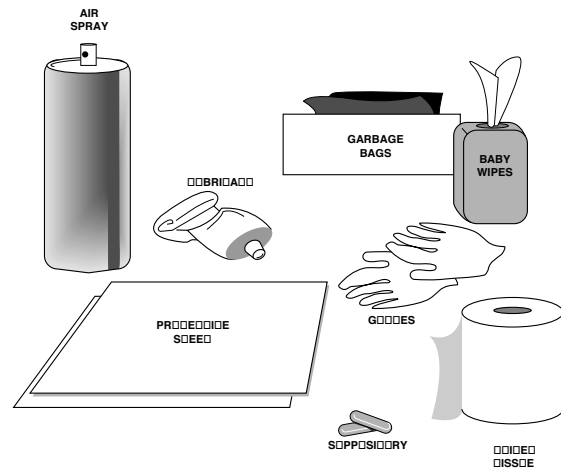

Procedure

1. Position yourself on the commode chair or toilet; or, if in bed, on your side (the left side usually works better).
2. If in bed, place a protective sheet or plastic bag under buttocks. You may use a paper towel or tissue to collect the stool.
3. If suppository is used, put some water-soluble lubricant on the suppository and with a gloved hand insert the suppository into the rectum as high up as you can reach. Be sure the suppository is in contact with the bowel wall, not embedded in stool. Allow the suppository to melt at least 10 to 15 minutes (if no suppository is used, go on to the next step).
4. Perform digital stimulation: Insert a well-lubricated gloved finger (or anal stimulator if used) into the anus about one inch, move the finger in a circle to stretch open the anus. Continue to stimulate this way for 3 to 5 minutes if necessary until the stool moves down and out of the anus. If there are no results after 5 minutes, rest for 10 minutes and try again.
5. If results are obtained, try again in 10 to 15 minutes until there are no more results.
6. If no results are obtained after one or one and a half hours, discontinue the procedure and try again the next day.
7. Cleanse the anal area and discard waste.

SECTION II

Remember:

- Perform your bowel program after a meal for best results.
- Drink something hot to stimulate bowels to move.
- Do not use a petroleum-based lubricant such as Vaseline.
- If you have hemorrhoids, you may try digital stimulation by pulling the anus sideways (towards the thigh) and holding for 1 to 2 minutes until you feel the sphincter relax.

MEDICATIONS

This chapter is focused on the things you should know about medicine.

Honesty is the best policy. The biggest part of the help you give is honesty. You will need to give your doctor a complete medical history and a list of your current medications, both prescription and over-the-counter. Your medical history tells your doctor what kinds of reactions, illnesses, and problems that you and your family have had. These are very important to them in understanding your past treatment and planning your future care. It is very important that you provide your doctor with a complete list of the medications you took at home and why you took them.

How Do Drugs Work?

The starting point of how drugs work is knowing that your body is mostly made of chemicals. Medicines are chemicals, too. When you take drugs, they mix with the chemicals of your body and help you.

Drugs work in two ways. One kind of drug works just the way it is, in the same form it was when you took it. Others work only after your body has broken them down into some other form so that they can mix with the chemicals and tissues in your body.

Most drugs are not things your body would normally use, so you eventually get rid of them through urine, bowel movements, tears, sweat, or your lungs. Each drug takes a certain amount of time to go through your body. This affects the dosage you are given. For example, some drugs pass very quickly through your body. Others are meant to build up and have a lasting effect.

Different Forms of Drugs

The drugs you take come in many different forms. There are tablets, capsules, syrups, chewables, shots, or ointments, to name a few. The form the drug comes in depends on how it is supposed to work in your body. Below are some examples of drug forms and how they are used.

- **Chewable tablets:** Fast-acting, often given to children
- **Swallowable tablets, capsules:** Long-acting. They must be swallowed whole so all the medicine is not released at once, but over time.
- **Injections:** For fast-acting effects or for drugs that cannot be taken orally and digested (like insulin and Lovenox).
- **Syrups:** Mostly cough medicines. They are usually thick, and may contain sugar.
- **Suppository/enema:** Medicines that are taken through the rectum. Used for those who cannot swallow medicine, or for medications that may cause nausea. Suppositories and/or enemas are also required for bowel programs. Bowel programs are discussed in the previous chapter.
- **Ointment/creams/lotions:** Mostly for skin conditions. An exception is nitroglycerin gel, sometimes used to treat autonomic dysreflexia.
- **Suspensions:** Contain large amounts of solid medication suspended in liquid. The solid tends to settle to the bottom, so you must be sure to shake the bottle before using in order to mix the contents.

What Does The Prescription Say?

Prescriptions are all roughly the same. For the most part, they include:

1. Your name and address.
2. "Rx" – the symbol marking the area where the actual prescription is written:
 - The name and strength of the drug and the quantity to be prepared.
 - The directions for how to take the drug (these are abbreviated on the prescription but will be written out for you on the drug container).
3. Refill information.
4. The date.
5. The prescriber's name, address, and registration number.
6. The prescriber's signature.

In most cases, your doctor will be able to give a drug order to the pharmacy over the phone. However, this cannot be done with prescriptions for controlled substances. These include such drugs as narcotics and stimulants. They can only be obtained with a written prescription taken to the pharmacy.

Side Effects

Most drugs are generally free from side effects, but many drugs can produce unwanted effects in certain situations. Undesired effects are classified in these ways:

Pharmacologic (FARM-ah-co-LODGE-ick) effects: These are the chemical side effects of the drug itself. They are predictable and controllable. In addition, many drugs do more than one thing in your body. The size of the dosage you are taking can make a big difference. In some cases, your body may just need time to adjust to the drug or its side effects.

Allergic reactions: Allergic reactions come in many forms, showing up immediately or even as late as several weeks after the medication is taken. Skin reactions are common symptoms of an allergic reaction. They range from redness and itching to swelling and sores. Allergic reactions have nothing to do with the action of the drug or the size of the dosage. They are often unpredictable in occurrence, except that people who have allergies such as hay fever tend to react more to medications. Reactions of this kind are a strong reason why your medical history needs to be complete. There may be less chance that a reaction will occur if your doctor knows about your past experiences with medications. If you do experience some kind of reaction to your medication, stop using it and call the SCI clinic or your doctor immediately.

Anaphylaxis (ANN-ah-fill-AX-is): A severe, immediate response to a drug. It is a life-threatening situation of decreased blood pressure and breath spasms. **CALL 911.**

Drug interaction: This refers to the effect two or more drugs have on each other. Sometimes, one drug helps another work. Other times, one stops the other. Occasionally, both keep working, but their actions combined create yet another reaction. Alcohol is likely the drug most often combined with other drugs. For example, alcohol more than doubles the effect of tranquilizers. Keep in mind that cough syrups contain enough alcohol to have the same effect. Again, the best policy is to tell your doctor about any drug you take on a regular basis. Even if it's just aspirin, it could make a big difference.

Your Medicine

You may never have taken medicines regularly. Your injury means you'll probably need to take some medicine every day. You need to know all about your medicines before you leave rehabilitation. Your nurse will help you learn about your medicines. Ask your nurse or doctor questions about your medicines (what is it for, what is the dosage, what are the side effects, etc.). You need to fully understand your medicines while you are at rehabilitation so you will understand and take them correctly at home.

The information you need to know about your medicine is:

1. The name of each medicine.
2. The reason for taking each medicine.
3. How much to take of each medicine.
4. When to take each medicine.
5. How to take each medicine (by mouth, shot, or in rectum).
6. Major side effects of each medicine.
7. Major precautions to take with each medicine.

You will probably be taking more than one medicine for a long time. There are things you need to do in order to manage your medicines and prevent complications.

Important practices to follow:

1. Put all of your medicines - both prescription and over-the-counter - in one place.
2. Give each of your doctors a list of all your medicines. Tell them about any changes on the list (see the form at the back of this chapter).
3. Continue to take your medicines until your doctor tells you to stop; some medicines can make you very sick if you stop taking them suddenly.
4. If you think you are having a reaction to your medicines, tell your doctor and follow his advice.
5. If you miss a dose of medicine, do not take an extra pill the next time it is due.
6. Ask your pharmacist about taking prescription and over-the-counter medicines together. Over-the-counter medicines include aspirin, Tylenol, ibuprofen, cold, sleep, and allergy medicines as well as medicines for constipation and diarrhea.
7. Do not use alcohol or illegal drugs without first checking with your doctor while you are taking prescription medicines. Even if prescription medicines are taken several hours before or after the alcohol or illegal drugs, the combination can make you severely ill and can even cause death.
8. Do not use other people's prescription medicines. Even if it is the same medicine, the strength may be different which may be harmful to your body.

When You Get Home

In the hospital, you may have many people around you to ensure that you take your medication safely. They tell you how much to take and when to take it. They will also tell you about what you are taking and how it works.

At home, you will be the only one responsible for your medicines. You are responsible for taking your medication on time and in the proper dosage. Be aware of any changes that may occur while you are taking your medications and let your doctor know about them.

Being responsible also means that you have to keep yourself informed about the medicines you're taking. Read the labels of everything you take. If you still have questions, ask your pharmacist. This applies to both your prescription and over-the-counter medications.

Pay attention to the details. The more aware you are, the safer your drug therapy will be, and the more effectively your drugs will work for you.

When you discharge from Carolinas Rehabilitation, only take the medicines prescribed to you. Do not add medications once you are home without clearing it with a doctor. (Medications you were once on may not be appropriate for you to take now.)

You will receive a list of medicines that you are to take at home. Take this list to all your doctor visits and all medical testing (example: lab, X-ray, MRI, CT). This list will help to improve communication between all healthcare providers as well as you and your family. It reduces confusion and improves medicine safety.

SECTION II

Here is a helpful sheet to organize medication information.

Name	Reason	How Much	When	How to Take	Side Effects or Precautions

PAIN MANAGEMENT

Following a spinal cord injury, 25 to 94 percent of people experience some kind of pain and about one third of people experience pain that impacts their daily function at some point in time. There are many different types of pain that can occur after a spinal cord injury. Pain can occur above your level of injury, at your level of injury or below your level of injury.

Musculoskeletal Pain

Musculoskeletal pain usually occurs above your level of injury. It is pain that affects the muscles, ligaments and tendons, along with the bones. It is the most common type of pain experienced at six months following injury (40 percent) and increases slightly through the years. Musculoskeletal pain may include mechanical instability of the spine. It may be impacted by body positioning in your wheelchair or in bed. It may be worsened by certain activities. Sometimes overuse of your upper extremities, such as pushing a wheelchair, will also lead to musculoskeletal pain in shoulders, wrists, and elbows. Musculoskeletal pain can sometimes be alleviated by changing your posture or positioning, changing the way you move, strengthening or stretching your muscles, thermal agents (heat or ice), massage, electrical stimulation units called TENS machines and/or oral medications.

Neuropathic Pain

Neuropathic pain typically presents either at your level of injury or below your level of injury and has likewise been described immediately after injury and can last for many years.

Neuropathic pain is caused by damage to or dysfunction of the nervous system. It cannot be explained by a single disease process or a single specific location of damage. Neuropathic pain may be associated with abnormal sensations called dysesthesias, which occur spontaneously, and allodynia, which occur in response to external stimuli like touching, pressure or movement.

At-level of injury neuropathic pain occurs within a band of two to four segments above or below the level of your spinal cord injury. It often occurs on the border of normal sensation and anesthetic skin. Below-level neuropathic pain is often triggered by deep input, such as from your bowel or bladder filling or pressure sores.

Neuropathic pain may have continuous and/or episodic (paroxysmal) components. The latter may feel like an electric shock. Common qualities of neuropathic pain include burning, coldness, electric, or "pins and needles" sensations, numbness and itching. Neuropathic pain is usually treated by either oral or topical medications but can be very difficult to eliminate with only some 40-60% of patients achieving partial relief.

SECTION II

Three Steps for Pain Management

Step 1: Determine existing problems and identify biologic and psychosocial contributors to pain and their influence on your pain experience. Determine the impact of pain on your overall function and adjustment to your injury.

Step 2: Identify your specific objectives such as; pain relief/reduction, decrease in muscle spasm frequency, severity and related pain, increase exercise tolerance and improve function, achieve independent living, return to work appropriate to level of functioning

Step 3: Develop an interdisciplinary pain management plan. Treat identifiable causes/contributors to pain (e.g., urinary tract infection, pressure sore, instability of spine). Relieve/manage symptoms such as spasticity and pain of undetermined pathology.

Reporting Your Pain

Our goal is to help you manage your pain as effectively as possible so you can reach your maximal ability and fully participate in your treatment and therapy. There are several different ways you can alert staff to your level of discomfort. You can report pain using a numerical scale or indicate which facial expression best reflects your pain. An example illustrating both of these scales is pictured below.

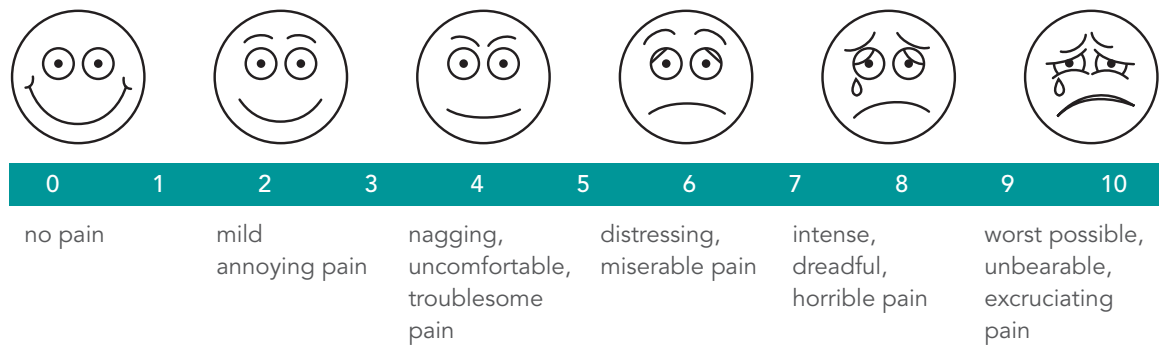

NUTRITION

A well balanced, nutritious diet is important to provide proper nutrient intake. Learning to select foods from the “Plate Method” will provide more variety in your diet. Each person needs to compare their present dietary habits with those they had prior to the injury. Individuals with spinal cord injury may need to change their intake of fiber, fluids or nutrients to help correct any problems with constipation, diarrhea, skin breakdown, etc.

Your metabolism will slow down 14 to 27 percent following your spinal cord injury in part due to a loss in your muscle mass. Because of this, your dietary intake should decrease as well. If you are paralyzed from your waist down (paraplegia), your daily intake should be roughly 28 cal/kg of body weight. If you are paralyzed from your neck down (tetraplegia) your daily intake should be roughly 23Kcal/kg of body weight. This will vary somewhat on your level of activity, skin integrity and medical conditions. (After discharge, if you suspect significant weight changes, keep a food diary and contact your physician). Ideally include: protein, carbohydrate, fat, fruits and vegetables. The American Heart Association recommends between five and nine servings of fruits and vegetables per day. Whole grains and fiber have been shown to decrease cardiovascular disease and diabetes mellitus.

This chapter will help you to:

- Identify the Food Groups and amounts needed of each.
- Learn where absorption occurs in the body.
- Identify foods that are good sources of fiber.

The Digestive System

The following is a brief review of how your digestive system works:

In the **mouth** the food is broken down and mixed with saliva. This prepares the food for digestion and makes swallowing easier.

The **esophagus** is a long muscular tube that pushes the food down to your stomach. The wave-like movement of the muscles pushing the food along the digestive tract is known as peristalsis.

The **stomach** churns the food and makes it semi-liquid.

Most absorption occurs in the **small intestine**. Tiny blood vessels in the intestine pick up the digested food particles (nutrients) and carry them throughout the body.

The food particles that cannot be absorbed by the body move down into the **large intestine**. Waste material is stored in the large intestine until peristalsis moves it through the rectum and out of the body.

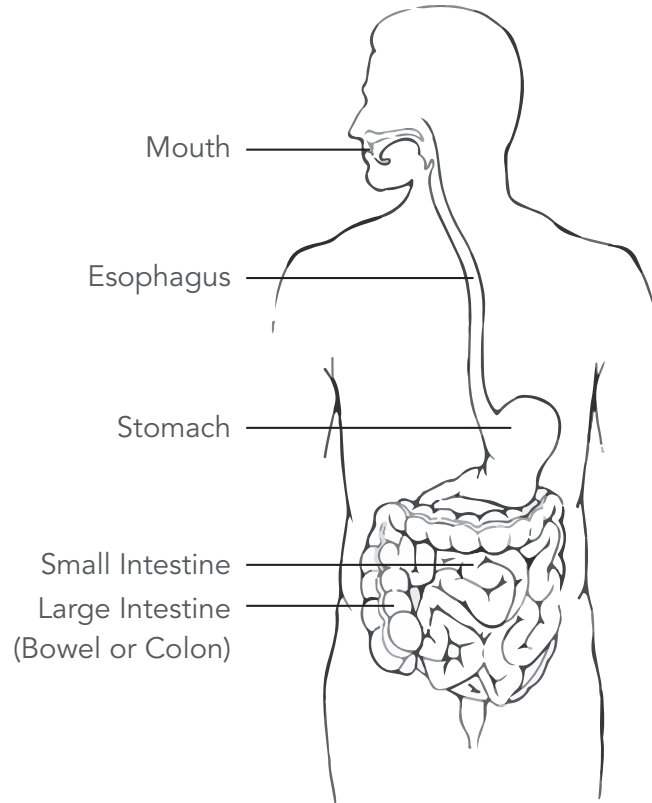

SECTION II

Nutrition Overview

The nutritional information in the chart below reflects the recommendations of the U.S. Department of Agriculture Center for Nutrition Policy and Promotion. For more information on these recommendations, visit www.choosemyplate.gov.



Vegetables	Fruits	Grains	Dairy	Protein Foods
<p>Eat more red, orange, and dark-green veggies like tomatoes, sweet potatoes, and broccoli in main dishes.</p> <p>Add beans or peas to salads (kidney or chickpeas), soups (split peas or lentils), and side dishes (pinto or baked beans), or serve as a main dish.</p> <p>Fresh, frozen, and canned vegetables all count. Choose "reduced sodium" or "no-salt-added" canned veggies.</p>	<p>Use fruits as snacks, salads, and desserts. At breakfast, top your cereal with bananas or strawberries; add blueberries to pancakes.</p> <p>Buy fruits that are dried, frozen, and canned (in water or 100% juice), as well as fresh fruits.</p> <p>Select 100% fruit juice when choosing juices.</p>	<p>Substitute whole-grain choices for refined-grain breads, bagels, rolls, breakfast cereals, crackers, rice, and pasta.</p> <p>Check the ingredients list on product labels for the words "whole" or "whole grain" before the grain ingredient name.</p> <p>Choose products that name a whole grain first on the ingredients list.</p>	<p>Choose skim (fat-free) or 1% (low-fat) milk. They have the same amount of calcium and other essential nutrients as whole milk, but less fat and calories.</p> <p>Top fruit salads and baked potatoes with low-fat yogurt.</p> <p>If you are lactose intolerant, try lactose-free milk or fortified soymilk (soy beverage).</p>	<p>Eat a variety of foods from the protein food group each week, such as seafood, beans and peas, and nuts as well as lean meats, poultry, and eggs.</p> <p>Twice a week, make seafood the protein on your plate.</p> <p>Choose lean meats and ground beef that are at least 90% lean.</p> <p>Trim or drain fat from meat and remove skin from poultry to cut fat and calories.</p>
<p>For a 2,000-calorie daily food plan, you need the amounts below from each food group. To find amounts personalized for you, go to ChooseMyPlate.gov.</p>				
<p>Eat 2½ cups every day</p> <p>What counts as a cup? 1 cup of raw or cooked vegetables or vegetable juice; 2 cups of leafy salad greens</p>	<p>Eat 2 cups every day</p> <p>What counts as a cup? 1 cup of raw or cooked fruit or 100% fruit juice; ½ cup dried fruit</p>	<p>Eat 6 ounces every day</p> <p>What counts as an ounce? 1 slice of bread; ½ cup of cooked rice, cereal, or pasta; 1 ounce of ready-to-eat cereal</p>	<p>Get 3 cups every day</p> <p>What counts as a cup? 1 cup of milk, yogurt, or fortified soymilk; 1½ ounces natural or 2 ounces processed cheese</p>	<p>Eat 5½ ounces every day</p> <p>What counts as an ounce? 1 ounce of lean meat, poultry, or fish; 1 egg; 1 Tbsp peanut butter; ½ ounce nuts or seeds; ¼ cup beans or peas</p>

SECTION II

Protein

You may need to increase your protein intake to help prevent tissue or muscle breakdown caused by spinal injuries, fever or surgery. At least two 4-ounce servings of a high protein food such as meat, fish, poultry, cheese, eggs, dried beans and dried peas should be consumed every day.

Protein is especially important if you have a pressure sore. Open pressure sores can involve tissue fluid loss which will cause increased protein loss. If you have a pressure sore, be sure your protein intake is increased to 100-120 grams per day,

Here is a brief list to help you measure your protein intake: (Figures are approximate)

Item	Serving Size	Grams
Meat, poultry, fish	2 ounces	14
Egg	1	7
Dried Beans	1 cup	14
Peanut Butter	2 Tablespoons	14
Milk	1 cup	8
Cheese	2 ounces	14
Bread/Cereals	1 serving	2
Vegetables	2 servings or 1 cup	4

NOTE: To limit saturated fat and/or cholesterol in your diet, avoid fried and processed foods. Choose meats that are lean, and milk and milk products that are low in fat.

Dairy Products

It is important to include normal amounts of dairy products in your diet as these foods are important sources of protein, vitamins and minerals. Occasionally patients may be concerned about calcium and kidney stones and want to limit or omit dairy products from their diet. This practice is NOT recommended. High calcium levels are the results of inactivity and the natural process of calcium leaving the bone due to a lack of weight-bearing on the bone.

The U.S. Recommended dietary allowance for calcium is 800 to 1200 milligrams per day. Common sources of calcium are listed in the chart on the next page.

SECTION II

Sources of Calcium

EXCELLENT SOURCES: 200 mg or more of calcium

FOOD	SERVING SIZE	CALCIUM (mg)
Cheese, Parmesan	1 ounce	383
Milk	1 cup	288
Yogurt	1 cup	275
Cheese, Swiss	1 ounce	262
Sardines	2 ounces	248
Cheese, cheddar	1 ounce	213

GOOD SOURCES: 100-200 mg of Calcium

FOOD	SERVING SIZE	CALCIUM (mg)
Cheese, American	1 ounce	198
Ice cream	1 cup	194
Macaroni and cheese	½ cup	181
Salmon – canned	1 cup	165
Custard	½ cup	146
Pizza – cheese topping	1/8 of 14" pizza	144
Turnip greens	½ cup	125
Beans, pinto	½ cup	123
Cheese, cottage	½ cup	106

Fiber

Daily dietary fiber intake helps promote normal bowel functioning and prevent problems of constipation and diarrhea. Whole grain breads and cereals, fresh fruits and vegetables provide the essential fiber in your diet.

The following is a list of high fiber food choices:

- Fresh fruits and vegetables (including the skins)
- Bran or bran cereals
- Whole grain cereals (including some granola)
- Oatmeal (whole oat)
- Bran or whole wheat muffins
- Whole grain, whole wheat bread, crackers, rolls
- Other whole grains (unrefined cornmeal, brown rice, whole barley, millet)
- Popcorn
- Raw nut and seed mixes with dried fruits
- Dry beans and peas (cooked)
- Tossed salads - containing dark green leafy greens and raw vegetables.
- Crunchy Peanut butter
- Whole wheat pasta

Fluids

The amount of fluid you drink is important and should be limited according to your bladder program. Fluids are important to prevent dehydration, keep your kidneys and bladder flushed, provide extra fluid when you have a pressure sore that is draining, and may also prevent formation of kidney and bladder stones. In general, limit your fluid intake to 2L of total fluid per day if you are on an ICP. Limit your fluid intake to 3L/day if you have an indwelling catheter. Water is your best choice!

Avoid excessive caffeine. Avoid excessive alcohol. Limit alcoholic drinks to no more than two drinks per day, not more than three days per week. Do not mix alcohol with spasticity medications like Baclofen, Zanaflex and Valium!

RESPIRATORY SYSTEM

The respiratory system includes the lungs and all the passages which bring air into and out of the body. The lungs are made up of thousands of tiny air sacs called alveoli and are lined with a moist membrane similar to the inside of your mouth. A network of blood vessels in the lungs collects oxygen from the air and distributes it throughout the body. Your body needs a constant supply of oxygen to stay alive. Breathing is so much a part of living that we don't even think about it until it becomes a problem.

When we breathe, our body does two things:

- when we breathe in (inhale), our lungs take in oxygen
- when we breathe out (exhale), our lungs get rid of carbon dioxide

The cells in our body need oxygen to live. Cells use the oxygen to “burn” food and turn it into energy so the cells can perform important jobs. Muscle cells get energy to lift objects, heart cells get energy to pump blood, and skin cells get energy to stand guard against infections.

Oxygen has to get to each and every cell in our body. It is our blood that carries oxygen from the lungs to every part of our body. The cells in your body “burn” oxygen for energy. When the oxygen is “burned” it is turned into a gas called carbon dioxide. This left-over carbon dioxide can poison us if we don't get rid of it. Our blood comes to the rescue again and carries the carbon dioxide from the cells back to our lungs. Then our lungs get rid of it when we breathe out. You can see that breathing in and breathing out are equally important.

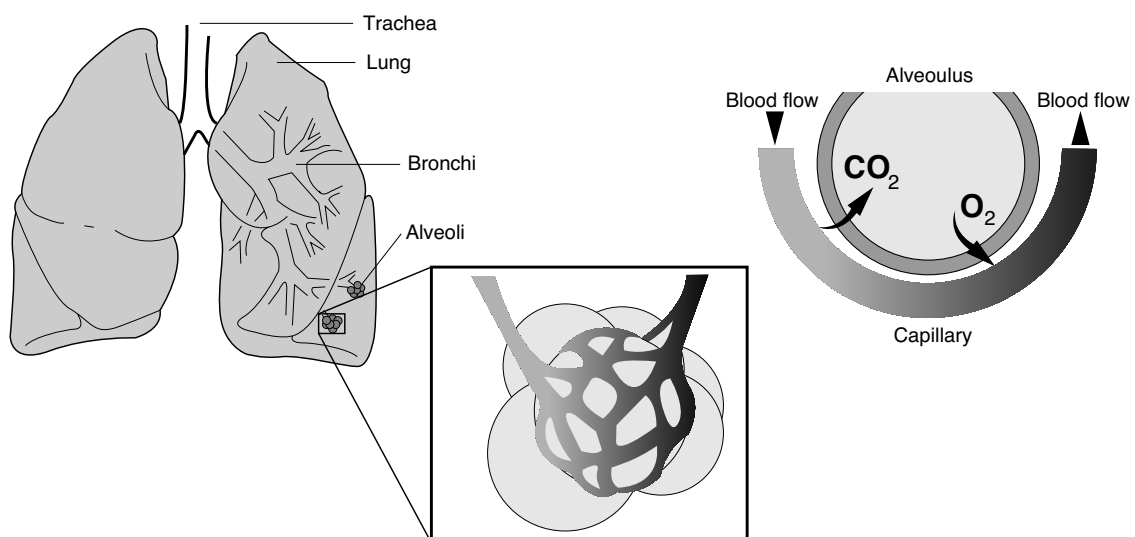

How Your Respiratory System Works

For breathing to work well, two parts of our body have to work well – our breathing system and our blood system. The medical name for our breathing system is the “respiratory system.” The respiratory system includes your mouth, nose, windpipe (trachea), and lungs. Air is inhaled through your mouth and nose, travels down your windpipe, and into your lungs.

The major muscle that you use to breathe is your diaphragm. This sheet of muscle is located below your lungs but above your stomach, and it is attached to your breastbone, ribs, and lumbar vertebrae. The lungs are soft and spongy. Around the lungs are airtight bags called pleura. The lungs have no muscles of their own. When you breathe in, your diaphragm moves downwards and your stomach bulges. When you are exercising and need to take in more air with deeper breaths, other muscles such as those in your neck, between your ribs, and in your stomach may help out.

The air you breathe in is filtered and moistened by mucous membranes in your mouth, nose and windpipe. There are tiny particles in the air you breathe, like dust for example. Hairs and mucus in your nose trap the particles so that they do not get into your lungs. The little hairs sweep the mucus into your nose and mouth to be swallowed, coughed up, sneezed or blown out. Moisture is added to the air from the mucus in your nose. This mucus can build up and become a problem. With a spinal cord injury, muscles that assist in breathing and the removal of mucus may be weakened.

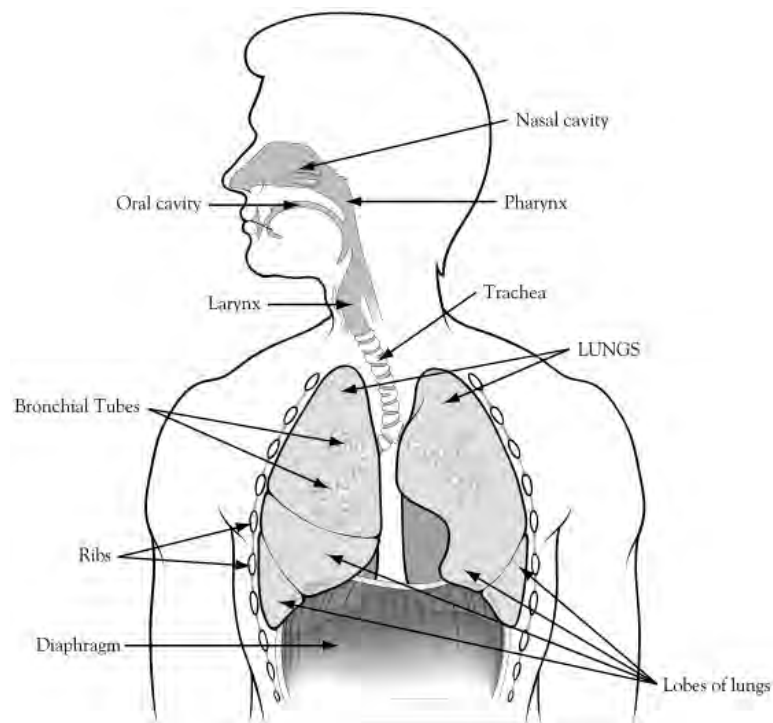

How Spinal Cord Injury Affects Breathing

If your spinal cord injury (SCI) is above T12, your breathing or coughing muscles may be weakened. The chart shows the effect that each level of injury has on your ability to breathe.

Level of Injury	Working Muscles				Effect on Breathing
	Accessories	Diaphragm	Intercostals	Abdominal	
C3 and above	partial	no	no	no	mechanical ventilation required
C4-C8	yes	yes	no	no	shallow breathing, no cough, paradoxical breathing, accessory muscles needed.
C8-T6	yes	yes	no or partial	no	shallow breathing, cough weak or absent
T6 – T12	yes	yes	yes	no or partial	weak cough
Below T12	yes	yes	yes	yes	no effect on breathing

A ventilator (or “vent”) is required for those with higher levels of injury. A ventilator is a device that mechanically pumps air in and out of the lungs for those who cannot effectively breathe on their own. Many times a tracheostomy (or “trach”) is needed to allow the air from the “vent” to reach the lungs. A “trach” is a tube that passes through an opening in the neck to the trachea (also known as the “windpipe”) below the vocal cords. Air no longer passes over the vocal cords, which makes speaking difficult without the use of certain devices. Proper care of the “trach” site is important to prevent infection.

Respiratory Complications

Respiratory complications that may result from impaired respiratory ability following a spinal cord injury include:

- **Collapsed Lungs:** The lungs cannot fully expand due to lack of moisture. Your doctor may prescribe medication for treatment.
- **Pneumonia:** A bacterial infection due to increased secretions in the lungs. Medication and/or antibiotics may be prescribed. Talk to your doctor about medications to treat pneumonia and the possible benefits of considering a flu shot. Make sure to drink adequate amounts of fluid to help keep secretions thin enough to clear.
- **Pulmonary Embolism:** A blood clot involving an artery that supplies the lungs. Symptoms may include shortness of breath and/or pain in your chest. Blood thinners are often prescribed to prevent and treat a pulmonary embolism. This can be a life threatening problem and you should seek immediate medical assistance.
- **Aspiration:** Inhaling anything other than air into the lungs. Persons with a spinal cord injury above T12 are at risk for this due to having a weak cough. Be aware of pollutants in the air including aerosol sprays and smoke. Use caution exercising outside in the summer and watch ozone reports. Maintain good posture when swallowing to avoid liquids or solid food from “going down the wrong pipe” or going into your lungs instead of your stomach.

Airway Clearance

A common problem after a spinal cord injury (SCI) involves the secretions (fluids) which coat the inside of the lungs and all the air passages. Normally, your daily activity and coughing keep these secretions moving up and out of the lungs. After a SCI, your decreased movement and weakened cough may allow the secretions to build up. They tend to block the air passages and become a breeding ground for infection.

If you have a problem with secretions, you will need to learn how to clear your airway. How much of this will be necessary depends on the level of your injury and on the amount of secretions you have. Even if you do not usually need respiratory assistance, you may need it when you have a cold, flu, or bronchitis. Secretion removal may be achieved with various methods.

Manual Assisted Cough

Assisted coughing simply means having another person help you breathe out forcefully in order to clear your air passages more effectively. It is performed very much like the "Heimlich Maneuver," which is commonly used to save people who are choking. The person helping you stands in front of or behind you if you are sitting, or over you if you are lying down, and pushes in and up on your diaphragm while you cough or breathe out as hard as you can. Make sure the wheelchair will not tip if you are sitting upright. The assisted cough is done until you can bring up any extra mucus or secretions into your throat where you can spit them out or swallow them.

It is very important to learn this technique from a healthcare professional to prevent injury. Avoid performing the assisted cough right after eating if possible – you may get sick. Do not push on the ribs or chest bone – this can cause internal injuries. Communication between you and your caregiver must occur to improve timing – push only when you are breathing out. It may be scary at first but a forceful push is required to perform an effective assisted cough. Work with a healthcare professional to decrease fears of causing harm and to determine appropriate cough assist techniques when tubes or injuries are present in the abdominal area.

Depending on your SCI, you may help yourself when coughing by pushing on your own stomach with your hands and flexing your upper body forward. A technique called forced expiration or "huffing with chicken wings" can be used for more independent airway clearance. This involves a forced exhale while using the upper arms to apply pressure to both sides of your rib cage. Receive more instruction from your healthcare professional.

Cough Assist Machine (Mechanical In-exsufflation or Insufflator/Exsufflator)

This machine is used to remove secretions or mucus from the throat or lungs. Air is gently blown into the lungs and then quickly sucked out to clear the airway, like a cough. The effectiveness of this machine is increased when followed by a manual cough assist when you have a trach, and tends to be preferred over suctioning because it is less invasive and more comfortable.

Suction Catheter

This is a narrow, flexible tube used to remove secretions from the airway when the assisted cough and cough assist machine do not work. It is a more invasive technique that can irritate your airway, increase risk for infection and create more secretions when performed too deep and too often. It is important to discuss the proper use of suctioning with your respiratory therapists. A bronchoscope is a tube with a light that can be used by physicians to look in the airway and remove secretions when the other methods are not working.

Positioning For Success

Allowing full movement of your rib cage will make it easier to breathe. Proper upright posture improves rib cage mobility. We can encourage good posture by placing a rolled up towel across the lower curve of the back (lumbar region) or across the “hump” in our upper back (thoracic region). A towel roll may also be placed up and down the spine to improve shoulder blade (“scapula”) positioning to further allow the lungs to expand. Towel rolls can be used when lying down or sitting in the wheelchair but be sure to monitor the skin under the towel rolls to prevent pressure sores. Remove extra pillows from under your head to decrease rounding of your upper body and collapsing of your chest. Ask your therapists for more positioning ideas.

Breathing Exercises

In order to keep your respiratory system as healthy as possible you need to strengthen the muscles that help you to breathe, stretch your lungs, and learn to produce an effective cough. Your breathing exercises must become part of your daily routine to help prevent lung infections and decrease your risk for life-threatening complications.

Deep breathing stretches the lungs and helps to get air behind the mucus so that you can cough more effectively. It is best done while lying on your back, but it can also be done sitting.

First, breathe in as deeply as you can, hold it for one or two seconds then breathe out. Repeat 6-10 times, doing normal relaxed breathing in between each set. There are other breathing exercises that your therapist may teach you to do.

You may be given a small “breathing exercise device,” called an incentive spirometer, which will help you strengthen your breathing muscles. The goal is to practice breathing in deep and controlled with this device to get the yellow marker in the “smiley face” zone. Your healthcare team can provide you with more instructions.

The Acapella is another breathing device that provides resistance to breathing out (positive expiratory pressure) and has a flutter valve that helps break up secretions to be removed from the lungs. Discuss the possible benefit of this device with your respiratory therapist.

Frog Breathing (or glossopharyngeal breathing) is a technique used by individuals that require a ventilator to breathe. It allows a person to breathe without the ventilator with the use of tongue and mouth muscles. This cannot be done with an open trach tube. The technique is difficult to describe and easier to understand with demonstration. You can get more information from your respiratory therapists or healthcare professionals if it applies to your condition.

More on Respiratory Management

Abdominal binders (like a corset) may be used to provide support to your weak or absent stomach muscles, especially when you are sitting. It is easier to breathe when your trunk muscles are held close to your body and your organs are supported. It must be correctly placed below the sternum (or “chest bone”) and above the belly button to be effective.

Percussion and drainage can be useful in certain situations. You are placed in a series of positions which allow gravity to help drain the secretions. Your caregiver taps firmly on your chest with cupped hands. This loosens the secretions from the lining of the air passages. The secretions work their way up to your throat, where they can be spit out or suctioned out if you cannot cough them up yourself. This can be labor intensive for caregivers and may be uncomfortable for patients.

Diaphragm or Breathing Pacemaker can be placed surgically to allow breathing without a ventilator in certain injuries. The diaphragm is a large muscle located at the base of the ribcage that must function for normal breathing to occur. The pacemaker stimulates a nerve called the phrenic nerve which causes the diaphragm muscle to contract. The phrenic nerve must be tested to determine if you are a candidate for this procedure, in addition to other respiratory tests. If you are currently using a ventilator, talk to your doctor about this treatment option.

Going Home on a Ventilator

Transitioning home from the hospital on a ventilator will be less stressful with the right equipment and supplies.

Necessary respiratory equipment may include:

- 2 portable ventilators
- Oxygen
- Emergency power supply
- Suction equipment
- Alarm systems or monitors
- Cough assist machine
- Emergency call systems
- Trach hygiene supplies

Around the clock care will be needed for anyone dependent on a ventilator. This can be accomplished with trained family and friends, or hired help. Preparing for emergencies at home will increase the safety of the ventilator dependent person. Contacting the local providers of emergency services (fire department, EMT services, local ER, etc.) and local power providers to explain your situation, the person's special needs, and respiratory equipment being used will be beneficial in a time of emergency. (Refer to Emergency Preparedness Section of this notebook)

How to Keep Your Lungs Healthy

Like most health problems, respiratory infections are easier to prevent than to cure. By getting into good habits, you can avoid serious illnesses such as pneumonia and improve your overall health and well-being.

- Do not smoke and do not allow others to smoke around you.
- Drink plenty of fluids (within your fluid limits).
- Get out of bed!
- Make sure caregivers wash their hands.
- Get your annual flu shot.
- Use your spirometer or take several deep breaths several times a day to fully expand your lungs and strengthen your breathing muscles.
- Avoid people with colds or coughs.
- If you do get a cold, do not stay in bed (get up) and practice your airway clearance techniques (such as assisted cough) as needed.
- See a doctor if you have a fever, shortness of breath, thick yellow or green secretions, or chest pain as these are signs of lung infection.

We Are Here to Help You Breathe Better!

Respiratory Therapists and your healthcare team can help you with your breathing problems. The Respiratory Therapist can measure how well you are breathing using several tests. Some people with breathing problems need help from breathing machines, breathing tubes, or extra oxygen. Our Respiratory Therapists set these up according to your doctor's orders, and they make sure that everything is running correctly. One of the most important things that our Respiratory Therapists will do is explain to you what is happening and why you are getting a specific test or special treatments for your breathing.

We encourage you and your family to ask questions and share any concerns you have with any member of the healthcare team working with you during your time at Carolinas Rehabilitation. You can find our Respiratory Therapists in the Respiratory Care Department.

References

1. Boitano LJ. *Management of Airway Clearance in Neuromuscular Disease*. *Respiratory Care* 2006;51(8):913-924.
2. Brown R, DiMarco AF, Hoit JD, Garshick E. *Respiratory Dysfunction and Management in Spinal Cord Injury*. *Respiratory Care* 2006;51(8):853-869.
3. Massery MP. *What's positioning go to do with it?* *Neurology Report* 1994;18(3):11-14.
4. McCool FD, Rosen MJ. *Nonpharmacologic Airway Clearance Therapies: ACCP Evidence-Based Clinical Practice Guidelines*. *Chest* 2006;129:250S-259S.
5. PVA. Consortium for Spinal Cord Medicine. *Respiratory Management Following Spinal Cord Injury: What You Should Know. A Guide for People with Spinal Cord Injury*. 2009.
6. Roth EJ, Stenson KW, Powley S, Oken J, Primack S, Nussbaum SB, Berkowitz M. *Expiratory Muscle Training in Spinal Cord Injury: A Randomized Controlled Trial*. *Arch Phys Med Rehabil* 2010;91:857

SKIN CARE

About Your Skin

Your skin covers and protects your entire body. It is made up of two layers of tissue.

The **epidermis** (epp-a-DURR-miss) or top layer consists of an outer part of dead cells and an inner part of living cells. The top layer acts as a buffer between the body tissues and the environment.

The **dermis** (DURR-miss) or bottom layer of skin consists of thick tissues which gives strength and elasticity to the skin. It has hair roots, sweat glands, oil glands, blood vessels, and nerve endings.

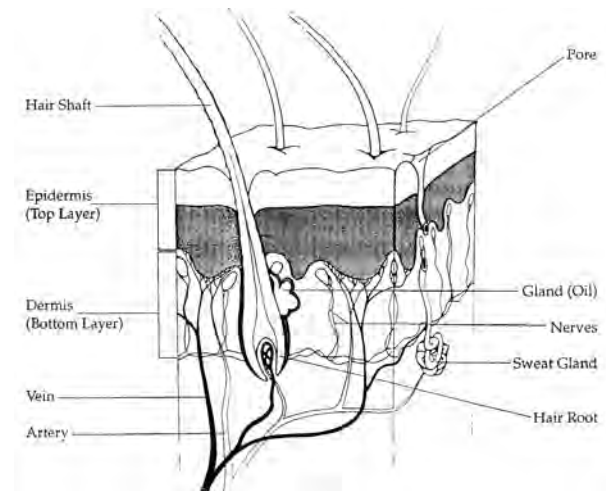

What Does The Skin Do?

1. Skin protects your body.
2. The nerve endings in your skin help with sensations.
3. Skin controls your body temperature and fluids. The skin does all this for all of the body structures and tissues beneath it.
4. Skin protects you by serving as a shield against germs, dirt, foreign objects – such as pebbles and ultra-violet rays from the sun.
5. Sensations of touch, pain, hot and cold travel from the nerve endings of the skin though the spinal cord to the brain.
6. Skin helps to regulate your body fluids and temperature. Sweat glands produce water and body salts. When moisture on your skin evaporates, it helps to regulate body temperature.

Pressure Sores

Circulation of your blood is needed to keep the cells of your skin and body tissues alive. When your circulation is cut off for a period of time, cells die and sores develop. The most common cause of this problem is pressure from your bed and wheelchair. These sores are called pressure sores.

SECTION II

How Pressure Sores Develop

The pressure of your body weight squeezes soft tissue between the bone and another hard surface. This could be your bed, wheelchair or your brace. Blood is pressed out of the tissue and circulation is blocked. Blood with its oxygen and nutrients cannot get past that point. Unless the pressure is relieved, the cells that are fed by those blood vessels will die, and a sore will form. Be aware that this kind of problem can arise in as short a time as 30 minutes.

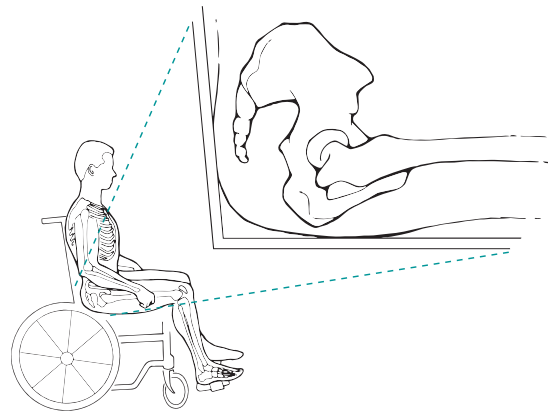

Other things that can cause pressure sores:

Shearing occurs when two layers of tissue right next to each other are pulled in opposite directions. This can also lead to skin breakdown. The blood vessels in the layers of the skin are closed off by the pulling.

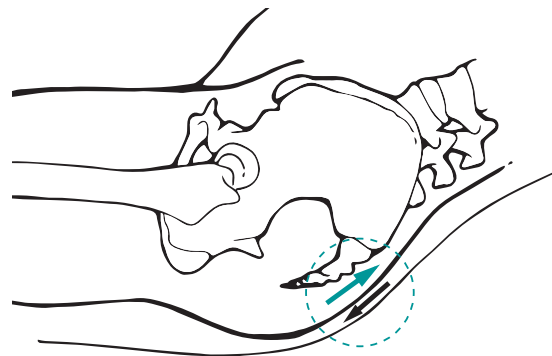

Shearing can happen if you slip down in your wheelchair. It also can happen when you sit in bed. If the head of your bed is elevated, you may slide down, which then can lead to shearing.

Shearing plus direct pressure from the weight of your body increases your risk of getting pressure sores.

Friction produced from constant rubbing or pulling of your skin across surfaces can cause blisters. It should be avoided. Friction occurs when you drag your hips across a bed, toilet, or other surface during a transfer. Friction can also be caused by spasms.



How To Prevent Pressure Sores

Regular pressure releases will allow the blood vessels to open again and prevent this. Fortunately, pressure causes changes in your skin which provide early warning signs that the cells are not getting adequate circulation. These early warning signs of damage are redness and firmness.

In the wheelchair, there are several ways to relieve the pressure on your buttocks:

Lean to one side then lean to the other side.

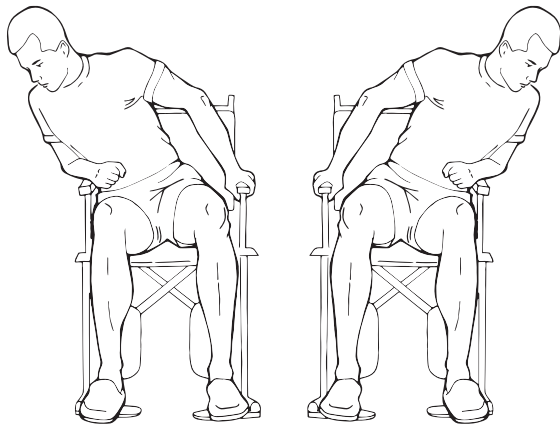

Lean forward and push up.

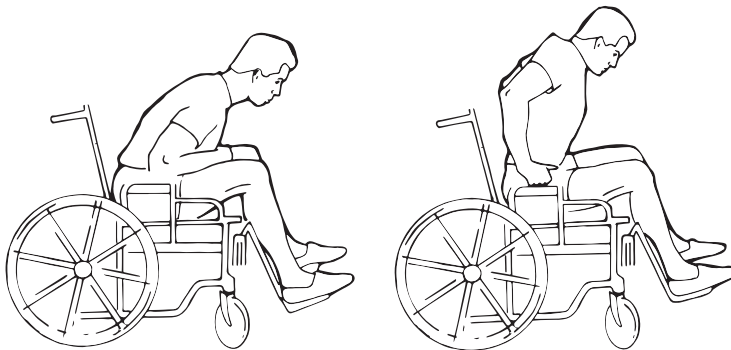

You need to do a pressure relief every 15 to 30 minutes for at least 30 seconds. When watching TV, many people do pressure reliefs during every commercial.

Using the proper wheelchair cushion can help spread the weight out which helps prevent sores. No matter which type of cushion you use, you need to do pressure reliefs.

In bed you relieve pressure by turning. When you are first in the hospital, you have to be turned at least every 2 hours. By the time you leave Carolinas Rehabilitation, you may be able to stay in one position longer. Your primary nurse will work with you to evaluate your skin's ability to tolerate longer times between turns.

Proper Positioning Prevents Pressure Sores

Proper positioning spreads your weight out correctly on your cushion or bed. If you sit or lie incorrectly you will put excess pressure on areas that can break down easily.

Sidelying (lying on your side)

- The areas which you must protect in this position are your trochanters (hipbones), sides of heels, and sides of knees.
- Use pillows and pads to position yourself on your side as shown in the diagram.

NOTE: Arms may need to be extended to prevent contractures.

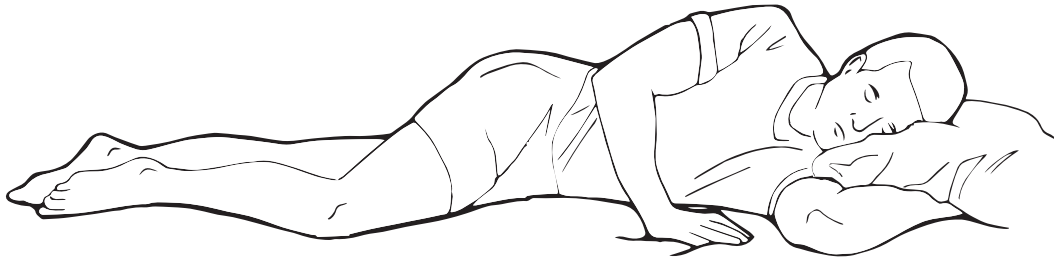

Supine (lying on your back)

- A major area for skin breakdown is your sacrum (the lowest part of your back). Another area is the backs of your heels.
- Check for pressure on your sacrum when you are lying down or are reclined in your hospital bed, propped up on pillows, reclined in your wheelchair or reclined in a reclining easy chair.
- Keep the sheets and blankets wrinkle-free.

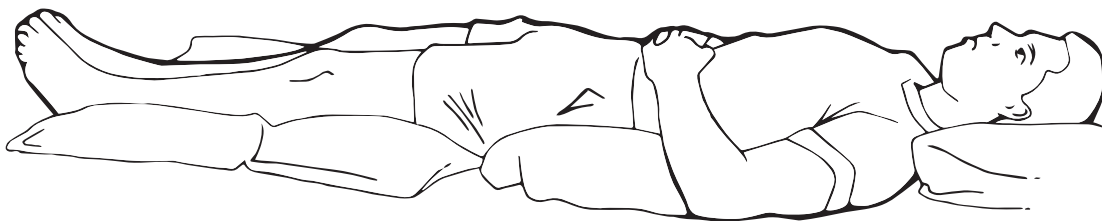

SECTION II

Prone (lying on your stomach)

Sleeping prone (on your stomach) is the best position in which to sleep because you will have a better chance of sleeping for eight hours without turning, and your knees and hips will be in a straight line, preventing contractures and decreasing spasticity.

- You may have to put a pillow under your head and chest and also protect your knees and toes with pillows or pads.
- Pads should not be placed directly under the knees or toes but on each side of the knees and under the ankles.
- If you have a bedside drainage bag, make sure you are not lying on the tubing.

NOTE: Arms may be placed at sides.

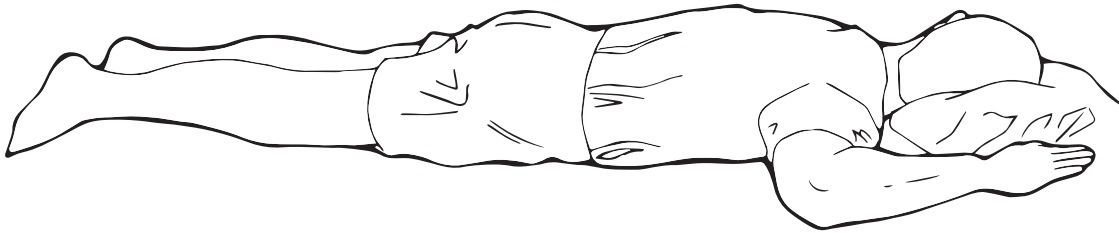

Three quarter prone

Proning or 3/4 proning (lying on your stomach) are excellent ways to relieve pressure at night for several hours. You can practice these during the day and evening until you are comfortable, then you can try it at night.

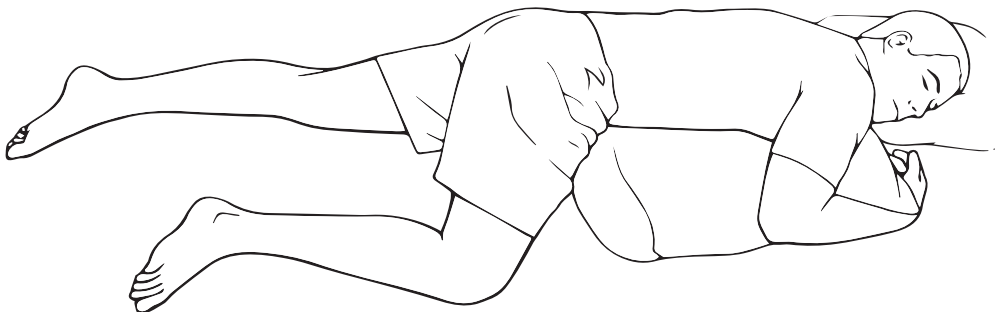

Positioning The Wheelchair



Correct

Your hips and knees should be level and you should be able to slide your hand under your lower thighs easily. Your feet should rest flat on your footrests.



Incorrect

Your knees should not be above or below your hips.

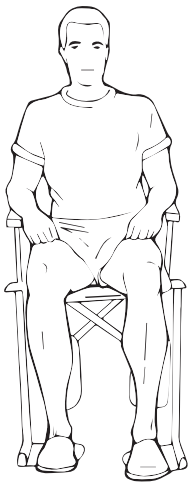

Correct

Your knees should be a few inches apart and in line with your hips.



Incorrect

Your knees should not be pressed together or spread far apart.

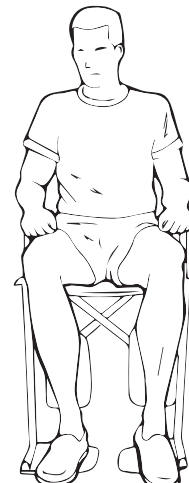

Skin Inspection

Twice per day, use a flex mirror to check your skin for red areas, bruises, scrapes, sores day. Do this before you get up in the morning and again when you go to bed.

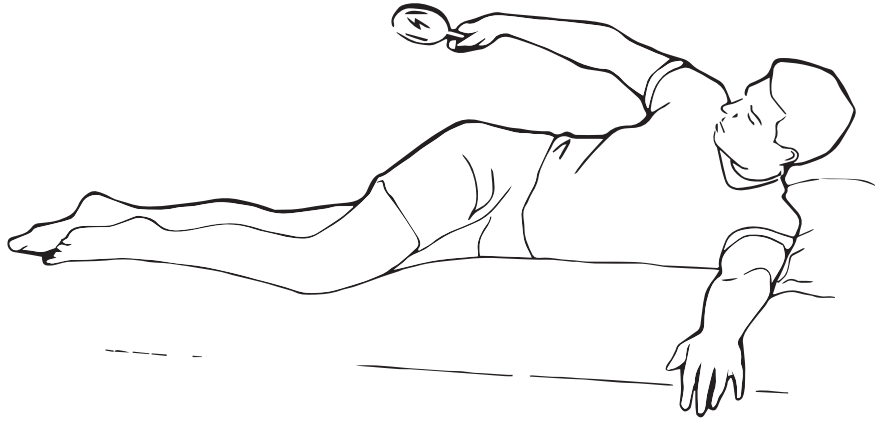

If you cannot use a mirror or check your skin yourself, get someone (like your attendant) to check those areas for you. Look for reddened areas, cuts, scrapes, and bruises. Anything that seems different needs to be carefully checked out. When you have been in bed, you need to check the parts of your body that have had pressure.

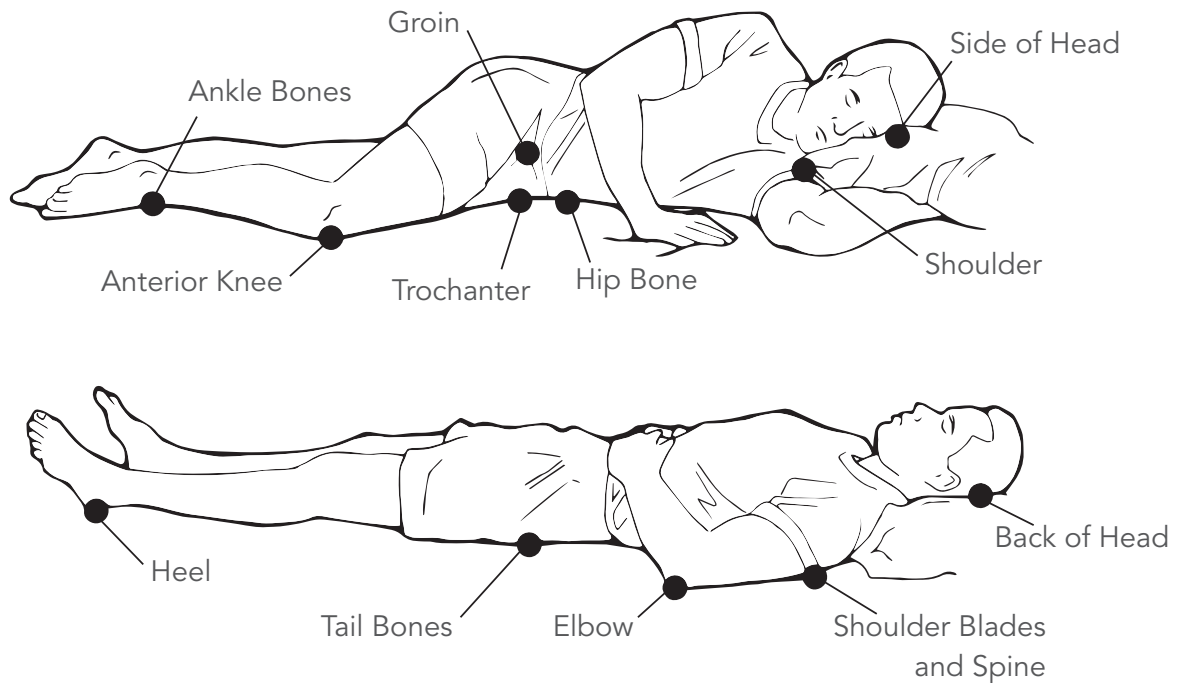

SECTION II

When sitting in your chair, you need to check the parts of your body that have had pressure.

If you find a red area or open area, you need to stay off the area. Do not sit on the area. Do not lie on the area. Call your doctor and tell him/her what the area looks like and its size. Your doctor will tell you how to take care of the area.

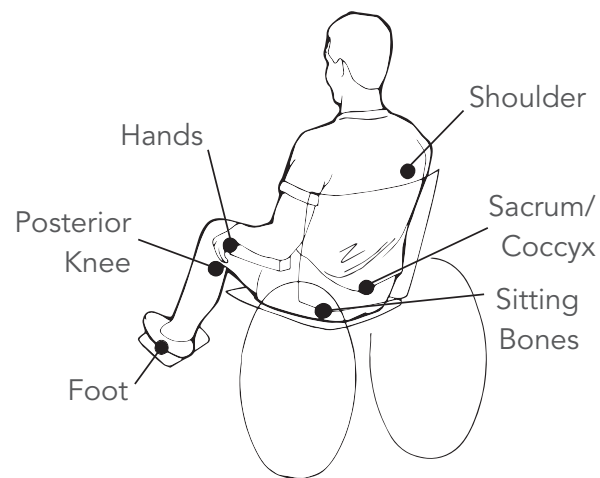

Keeping Your Skin Healthy

Nutrition for the skin

Vitamins A, E, and niacin (NIGH-ah-sinn) are some key vitamins that are necessary for proper development and maintenance of healthy skin. These vitamins cannot function alone. They require adequate protein, calories, and other vitamins and minerals to carry out their function. These nutrients can be obtained by eating a well-balanced diet and a variety of foods. Some tips on how to eat a well-balanced diet can be found in the section on nutrition.

Weight control

Weight control is another area of concern for skin care. Being at an appropriate weight for your height will help lower your risk for skin breakdowns. To get an idea of what an appropriate weight for your height is, see the "Nutrition" section. If you are underweight or overweight, see this section for tips on how to achieve your ideal weight.

Hygiene tips specific to SCI

Sitting in a wheelchair all day long with infrequent weight shifts doesn't give air much of a chance to freely circulate in the groin area. Also, having your legs close together most of the day gives those normal body germs what they like most – a nice warm, dark, moist place to reproduce. And, if you're wearing some sort of plastic or rubber urine collecting device, such as a condom catheter, Foley catheter, waterproof padding, or leg bag, the chance of making that breeding ground more enticing to germs increases.

Helpful Hygiene Tips

1. Wash and rinse your skin every day (if your skin is very dry, you can bathe every other day).
2. Wash your groin area before going to bed at night.
3. Air out your groin area at least once a day by getting into the frog position.
4. Thoroughly dry your skin after each bath.
5. If you are used to taking showers, try taking a warm tub bath once in a while if possible.
6. For any dry skin areas, massage in some lotion to soften it up. Dry skin can crack and cause healing problems.
7. If you like to powder, lightly dust some on your groin area. Be careful not to put on a lot. Too much powder can cake and cause lumps which could lead to pressure sores.
8. When clothes or sheets get wet or soiled, change them immediately.
9. Do your bowel and bladder program consistently so accidents can be avoided.
10. Rinse all soap off your skin because soap left on your skin can dry and irritate your skin.

For Incontinence Care

1. No briefs in bed. Briefs should be used only on incontinent patients for therapy, ambulation, off unit for procedures or per family / patient request.
2. Have appropriate products at bedside.
3. Use a Dri-flow pad ONLY if the patient is incontinent.
4. Fitted sheet, draw sheet and Dri-flow pad. NO reusable under pads.

Foot Care

1. Check your feet daily for red areas or open sores (including blisters).
2. Wash your feet daily, rinse and dry completely.
3. Apply lotion to your feet at night before going to bed. This way the lotion has time to be absorbed.
4. Clean finger and toenails daily.
5. Keep your nails short for safety.
6. Cut your nails straight across to prevent ingrown nails.
7. Cut your nails after soaking them for 15 to 20 minutes or after taking a bath. This makes them easier to cut.
8. Thick nails may need to be cut by a podiatrist.
9. Check for ingrown toe nails; if they develop contact your doctor.

Edema Management

Spending too much time in bed or in sitting without moving can lead to an increase in swelling of your hands and feet. This happens because the fluid in your arms and legs needs your muscle contractions to “pump” it back toward your heart for removal.

Extreme swelling will decrease the circulation to your skin making you more likely to develop skin problems. It also makes your legs or arms heavier and more difficult to move. If swelling becomes a problem for you the three best ways to manage it are:

1. Elevate your legs – either using elevating leg rests in your wheelchair or elevating them when you rest in bed.
2. Apply compression stockings – these help take the place of your muscle contractions to help push the fluid back to your heart. Two places in Charlotte, NC where you can purchase stockings with a prescription from your doctor are:

Compression Works, Inc,

906 Pecan Avenue
Charlotte, NC 28205
704-376-5353

Hanger Prosthetics and Orthotics

2034 Randolph Road Suite 100
Charlotte, NC, 28207
704-377-7099

3. Exercise – move as much as you are able to keep your heart and all available muscles working to “pump” fluid out of your legs and arms.

NOTE: Unusual swelling in only one arm or leg (asymmetrical) can be a sign of a blood clot (DVT) which is much more dangerous and requires immediate medical attention.

One

SECTION III

ADAPTIVE EQUIPMENT

You may need adaptive equipment, special tools made to increase your independence with activities of daily living, to help you because you may not be able to do things as you did before.

Adaptive equipment can be used in:

Eating

- Spoons, forks, knives with special handles.
- Plate guards to help you scoop.
- Special cups which you can hold yourself.
- Long straws if you cannot reach the table.
- Special cuffs you wear to hold spoons, forks, knives.

Writing

- Special holders or built-up grips handles for pens, pencils.
- Special pointing tools to type on a keyboard or turn the pages of a book or magazine.

Dressing

- Dressing sticks so you can reach to your feet to initiate putting on your pants or assist in removing your socks.
- Sock aid to pull on your socks.
- Button hook to button and unbutton shirt.
- Dressing ladder to make it easier for you to move around in bed.
- Velcro fasteners or elastic shoe laces when you cannot tie your shoestrings.
- Loops in your clothes if you cannot grab onto your clothes.
- Zipper pulls.

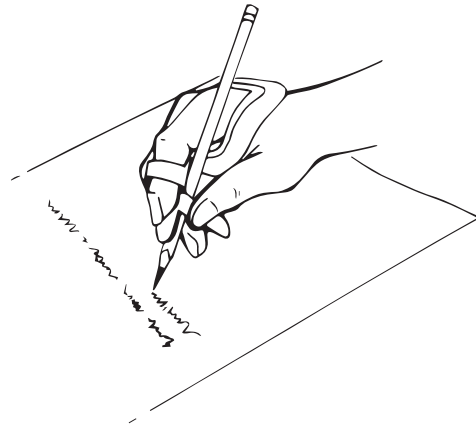

SECTION III

Grooming

- Long-handle sponges if you cannot reach where you need to or bath mitts if you cannot hold a wash cloth.
- Special handles for toothbrushes, combs, razors and hairbrushes.

Cooking

- Mirror over the stove so you can see into pots from your wheelchair.
- Special tools to open jars.
- Special reaching tools (called “reachers”) to help you pick up things that are too far away.

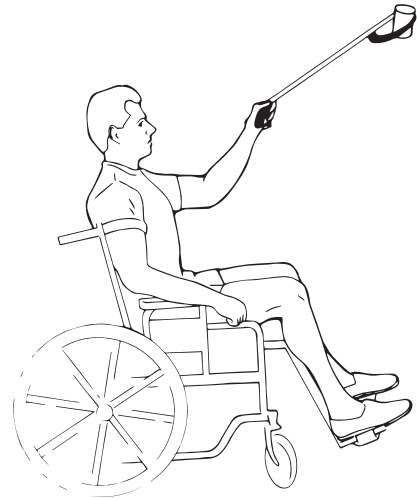

Other Adaptive Equipment

- Prism glasses so you can look straight down if you can't bend your neck forward.
- Mouthsticks if you cannot use your hands at all.
- Telephone holders or a speaker phone if you cannot hold the phone by yourself.
- Book holders to position a book for reading.
- Leg lifters or leg loops to help you get in and out of bed and to help you reach your legs during bathing and dressing.

Environmental Controls

- Special electronic devices to turn on radios, TVs, lamps, etc., without having to get out of your chair or bed.

These are just a few examples for the many adaptive equipment options available. Talk with your occupational therapist about your needs. The therapist can help you decide what adaptive equipment might be helpful to you.

You will be responsible for knowing proper use and care of your adaptive equipment and/or wheelchair. You will be responsible for directing others in set up and/or care of your adaptive equipment or wheelchairs if you are not physically capable of this yourself. Proper use of adaptive equipment and/or wheelchairs should increase your independent level of function, and increase your feelings of self-esteem and wellness. Similarly, use of adaptive equipment and/or wheelchairs may provide physical exercise, which will affect your physical fitness and overall wellness level.

SECTION III

HAZARDS AND SAFETY PRECAUTIONS

BATHROOM	
Cause	Bathtub, shower
Hazard	Burns
Solution	Adjust water temperature before bathing. Do not change temperature while bathing. Possibly use a hydro-guard or temperature control faucet. Be aware, when you are drawing your bath or are in the shower, if someone else starts a dishwasher or washing machine, etc., the water temperature may change quickly. The cold water may be pulled out of the line, leaving hot water that could scald you.
Cause	Transferring
Hazard	Falls
Solution	Use grab rails that are properly installed. Drain water and dry yourself while in the tub to prevent slipping while getting out of the tub.
Cause	Bathtub – Non-skid strips
Hazard	Abrasions
Solution	Be careful not to slide over strips as they can scrape the skin.
Cause	Water pipes
Hazard	Burns
Solution	Insulate pipes under the sink to prevent burning your legs.

BEDROOM	
Cause	Bed transfers
Hazard	Bruised, scrapes
Solution	When transferring, be careful not to bump, bruise or scrape your skin. Wear some type of clothing or use a towel or talcum powder when using a sliding board.
Cause	Electric blankets, heating pads
Hazard	Burns
Solution	Do not use heating pads or electric blankets.

SECTION III

CAR OR VAN	
Cause	Car heater
Hazard	Burns
Solution	Be careful of car heaters. Have someone with normal sensation check for heat and help you determine a safe position for your legs and feet.
Cause	Floor boards
Hazard	Burns
Solution	Always wear shoes when riding in a car.
Cause	Loss of balance while riding in or driving a car
Hazard	Losing control of car
Solution	Always wear seat belts and shoulder restraints, and use head supports when driving or riding as a passenger.
Cause	Car upholstery, metal parts
Hazard	Burns
Solution	In hot weather, avoid resting bare skin on hot upholstery, door handles, etc.

CLOTHES, BRACES, SPLINTS	
Cause	Jeans
Hazard	Pressure or abrasions
Solution	Check skin under seams and pockets. Seams may need to be trimmed to prevent pressure areas and abrasions.
Cause	Keys, coins
Hazard	Pressure areas
Solution	Do not put items in pocket of pants.
Cause	Braces
Hazard	Pressure areas
Solution	Build up your skin tolerance to wearing braces or splints. Be sure to check your skin after removing brace.

SECTION III

HOT WEATHER	
Cause	Hot weather
Hazard	Heat stroke
Solution	High paraplegics and most quadriplegics will have trouble in maintaining a normal temperature in hot weather because their body has a reduced area for perspiration and they do not lose heat as well. Stay out of the sun during the warmest part of the day and avoid any heavy exertion. Increase fluid intake. Bathing in tepid water and turning a fan on will reduce body temperature. Some people may require air conditioning in their home and car to regulate their temperature.

KITCHEN	
Cause	Cooking
Hazard	Burns
Solution	Be cautious when handling hot liquids. Slide the pans – do not lift them. Use a wooden, not a metal, tray to carry hot items. Insulate pipes under sink if your sink has an open area.
Cause	Foods
Hazard	Burns
Solution	Finger foods such as pizza, french fries, or chicken can cause burns if you have little or no sensation.
Cause	Microwaves
Hazard	Burns
Solution	Be aware that the bottom of cookware will be extremely hot. Do not set cookware on your lap.
Cause	Wood stoves, heaters, vents, fire-places
Hazard	Burns
Solution	Be cautious around heat. You may burn more easily after your spinal cord injury than before. Be aware that the handrims on the wheelchair can become extremely hot when sitting near a fireplace, wood stove, heater, vent, etc.

RAMPS	
Cause	Very steep ramps
Hazard	Falls
Solution	If a ramp is very steep, have someone lower you backwards to prevent falling forward out of your wheelchair.

SECTION III

SMOKING	
Cause	Cigarettes, cigars
Hazard	Burns
Solution	It would be to your benefit to give up smoking. Otherwise, use a robot smoker or cigarette holder. Never smoke at night when lights are out. Be sure ashes or matches don't fall on your clothes. Do not rest a thin metal ash tray on your lap.

WHEELCHAIR	
Cause	Wheelchair
Hazard	Falls, bruises
Solution	Keep wheelchair in good working order. Make sure brakes lock adequately for transfers.
Cause	Wheelchair
Hazard	Burns, frostbite
Solution	Your wheelchair upholstery and metal parts will get hot or cold in extreme weather. Wear adequate clothing to protect yourself in cold weather.
Cause	Wheelchair
Hazard	Burns (from wheelchair parts)
Solution	Be cautious around fireplaces, wood burners, stoves and radiators.
Cause	Reaching
Hazard	Falls
Solution	If you lean too far forward, you may fall out of your wheelchair. Stay back in your wheelchair or use a "reacher".

SECTION III

MISCELLANEOUS	
Cause	Hair dryers, other electrical appliances
Hazard	Burns
Solution	Be cautious when using appliances which may cause burns.
Cause	Rough areas – gravel, mud, sand, high grass
Hazard	Falls
Solution	If you run into high grass, mud, sand or gravel and can't propel, have someone tilt the wheelchair back by stepping on the tipper lever and pull back and down on the hand grips to propel through rough terrain.
Cause	Curbs
Hazard	Falls
Solution	<p>Be cautious when propelling a wheelchair on streets or sidewalks to not propel wheelchair off the edge of the curb.</p> <p>If you are with someone and you want to go up the curb, have them fade the wheelchair to the curb, tilt wheelchair back onto the back wheels and place front wheels on curb. Have them use hips and leg to push you onto the curb.</p> <p>To go down a curb, have someone back off the back wheels first, hold the handles and let the back wheels down first using their weight to lower wheelchair down. Step on the tipper bars and turn the wheelchair off the curb.</p>
Cause	Streetcrossing
Hazard	Bodily injury
Solution	Be cautious when crossing streets in a wheelchair.

MOBILE TECHNOLOGY AND SPINAL CORD INJURY

This list was last updated in July 2012. The list provides a small sample of all of the mobile applications that are available.

CELL PHONE AND TABLET ACCESS			
Name of Application or Tool	Cost	Device	Description
Siri App	Free	iPhone 4S	Use speech to manage basic iPhone functions such as phone pad, keyboard, calendar and web browser
Dragon Dictation and Dragon Search App	Free	Apple	Use speech to type, search and navigate on your mobile device
Flex T9 App	\$4.99	Android	Change keyboard into a four-in-one keyboard with the ability to access the keyboard by speaking, writing, tracing or tapping
A Special Phone App	\$.99	Apple	Create a phone list of up to six contacts. Dial the contacts by shaking the phone once for contact one, twice for contact two, etc.
Headset Button Control App	Free	Android	Manage your phone/music via a single button on your headset including volume, song skip and answer phone calls
Pogo Stylus	\$14.95	Any device with a touch screen	Use a stylus made with a special conductive material to access your touch screen devices www.tenonedesign.com
iFaraday straight and serpentine stylus	\$20.00	Any device with a touch screen	Use both the straight or serpentine stylus as a mouthstick or a hand based tool to access your touch screen devices www.ifaraday.com
iPad steady stylus	\$40.00	Any device with a touch screen	Use the T-handle as a hand-based stylus www.etsy.com/shop/shapedad

SECTION III

CELL PHONE, TABLET, AND LAPTOP ACCESS: MOUNTING SYSTEMS			
Name of Application or Tool	Cost	Device	Description
Ram Mounting System	\$35-\$300	Laptops, tablets or smart phones	11 different wheelchair mounts for electronic devices www.ram-mount.com
CJT Mounting	\$300-\$1200	Laptops or tablets	Mounts for wheelchairs, tables and floor mounts www.cjtmounting.com
Stealth Products	\$555	iPads	Wheelchair mounts for tablets www.stealthproducts.com
Daessy Mounting Systems	\$600-\$1200	Laptops and tablets	Mounts for electronic devices for wheelchairs, tables and floor mounts www.daessy.com

Not all mounting systems are compatible with tilting wheelchair systems. Please work with your wheelchair vendor to select the mount that is the best fit for you

HEALTH AND MEDICAL MANAGEMENT			
Name of Application or Tool	Cost	Device	Description
wsTimer App	Free	Apple	Program alarm reminders to perform pressure relieving weight shifts
waterlogged or WaterLog App	Free	waterlogged for Apple, WaterLog for Android	Tracks amount of water intake
Instant Heart Rate App	Free	Apple and Android	Get an instant reading of your heart rate by holding your finger up to your device's camera
Pill Box Alert and Rxmind Me Medicine Reminder and Pill Tracker App	Free- \$1.99	Pill Box Alert for Android, Rxmind me for Apple	Program your phone to provide reminders to take medications
Calorie Counter or Calorie Tracker App	Free	Calorie Counter for Android, Calorie Tracker for Apple	Track your calorie intake

There are numerous applications that will assist you with tracking exercise and nutrition

SECTION III

REHABILITATION TOOLS AND GAMES			
Name of Application or Tool	Cost	Device	Description
Touch Trainer App	\$6.99	Apple	Work on finger coordination by touching targets of varying size and locations
B-Boy Beats Game App	\$2.99	Apple	Work on finger coordination by playing a game similar to Dance Revolution but with your fingers
Labyrinth or aTilt App	\$2.99	Labyrinth for Apple, aTilt for Android	Work on grip and hand coordination by tilting or twisting your device to move a ball through a maze towards a target

TRAVEL AND WORK			
Name of Application or Tool	Cost	Device	Description
Jumbo Calculator App	Free	Apple	Large button calculator which decreases finger coordination requirements
Parking Mobility App	Free	Android, Apple, and Blackberry	Take photos of illegally parked cars in designated handicap spots and send to your city's parking services
CitiRollers App	Free	Apple, also available as a website	Allows wheelchair users to locate, add and rate accessible points of interest such as restrooms, public transit and restaurants for major cities
Wheelmap and Wheelmate Apps	Free	Apple and Android	Rates accessibility of local businesses and location of public toilets and parking

SECTION III

SPINAL CORD RESOURCES			
Name of Application or Tool	Cost	Device	Description
Americans with Disabilities Act (ADA) Reference Apps	Free- \$.99	The ADA Reference for Apple and ADA: Disabled Service Members for Android	Provides summary of ADA Act of 1990 with frequently asked questions
Quick ADA App	\$1.99	Apple	Provides information on specific regulations and codes that meet ADA standards, comes with illustrations and measurements of ADA compliance structures such as ramps, doors and hallways

UPPER AND LOWER EXTREMITY RANGE OF MOTION

What is range of motion?

Range of motion means the amount of movement you have at each joint. Every joint in the body has a “normal” range of motion. Joints stay loose by being moved. If you have a spinal cord injury and can’t move your arms and legs, your joints can become stiff and hard to bend.

Why is good range of motion important?

It is very important to move all your joints every day so they stay loose. Stiff joints can cause pain and permanent deformities. Stiff joints can also make it hard for you to do your normal daily activities. For example, if your knees and hips become stiff, it will be hard for you to dress yourself and to sit in a wheelchair.

What things can you do to keep good range of motion?

Your physical and occupational therapists will teach you any exercises you should do to keep good range of motion. Some patients may need a splint to keep the muscles around a joint stretched. Your therapist will give you a splint if needed.

UPPER EXTREMITY PASSIVE RANGE OF MOTION EXERCISES

These exercises show someone else how to stretch your arms if you are unable to move your arms by yourself. These exercises should be done slowly and gently, and can be done with the person sitting in a chair or lying down.

Do each exercise five times.

Shoulder Flexion

Place one hand on the shoulder. Turn the person's palm inward and lift the arm over the head.

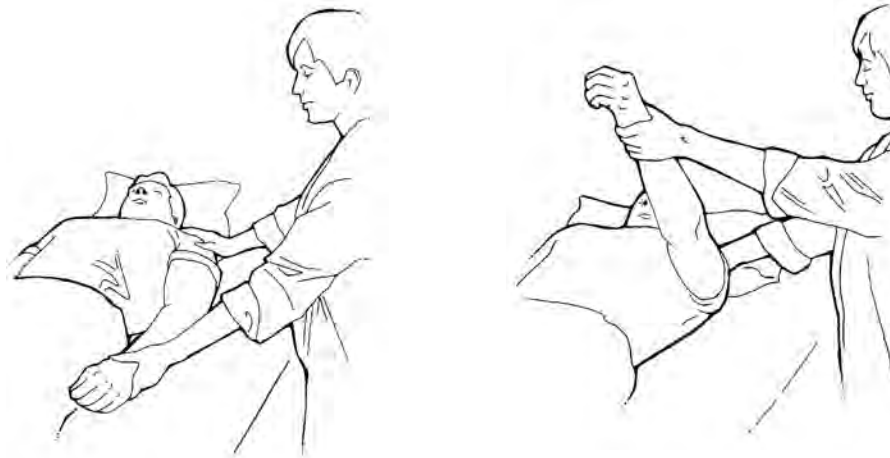

Shoulder Abduction

Place one hand on the shoulder. Use the other hand to turn the palm outward. Then, bring the person's arm out to the side.

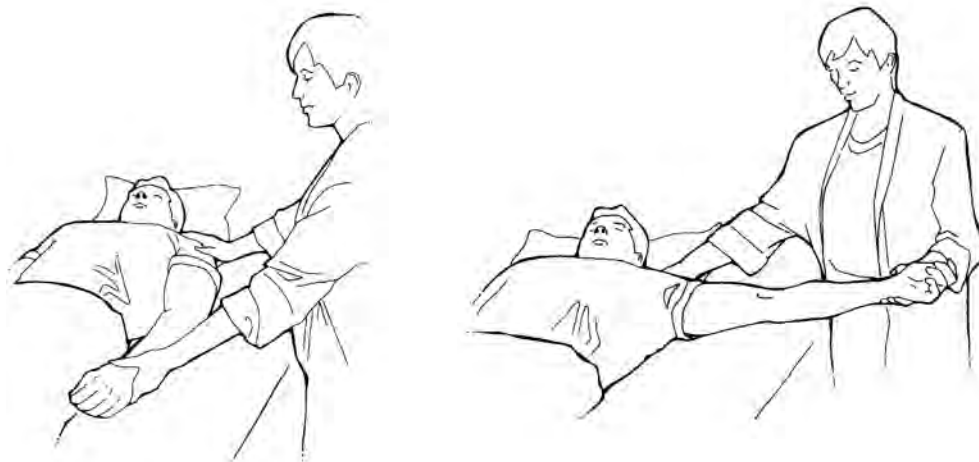

Shoulder Internal and External Rotation

Place one hand on shoulder or elbow. Hold wrist with your other hand. Bring arm out to side to shoulder level with elbow bent. Turn arm so hand points to towards head. Then turn arm back down so that hand points towards feet.

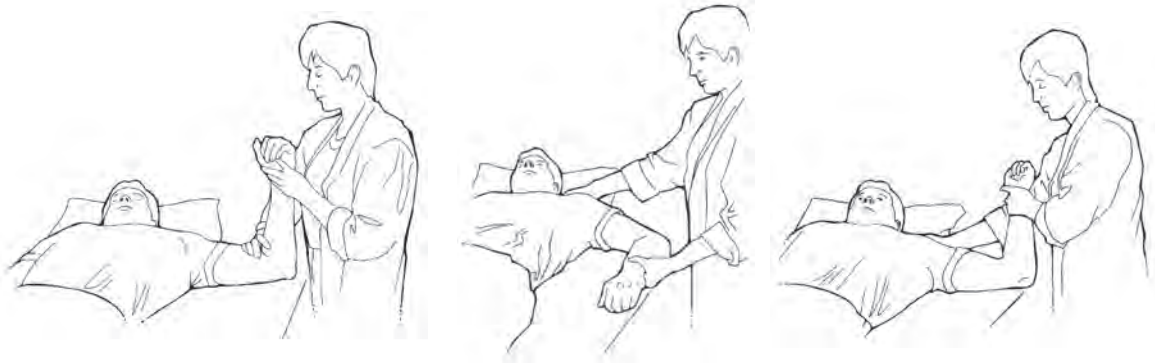

Horizontal Adduction and Abduction

Place one hand on elbow. Hold wrist with your other hand. Bring arm out to side to shoulder level with elbow bent. Bring arm across chest.

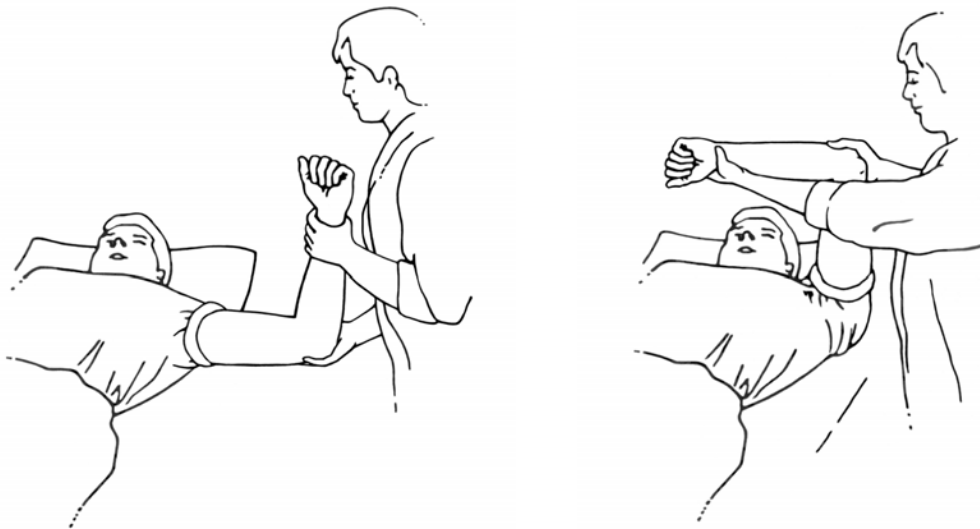

Elbow Flexion and Extension

Hold upper arm with one hand and forearm with the other hand. Bend arm at elbow so that hand touches shoulder, then straighten arm all the way out.

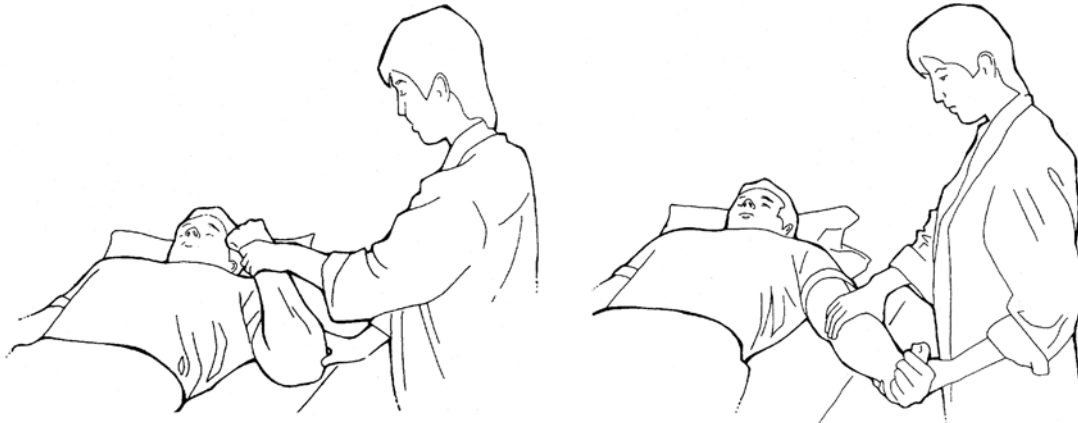

Forearm Supination and Pronation

Hold under the elbow with one hand. Hold at wrist with the other hand. Turn palm of hand so it faces up to the ceiling and then down to the floor.

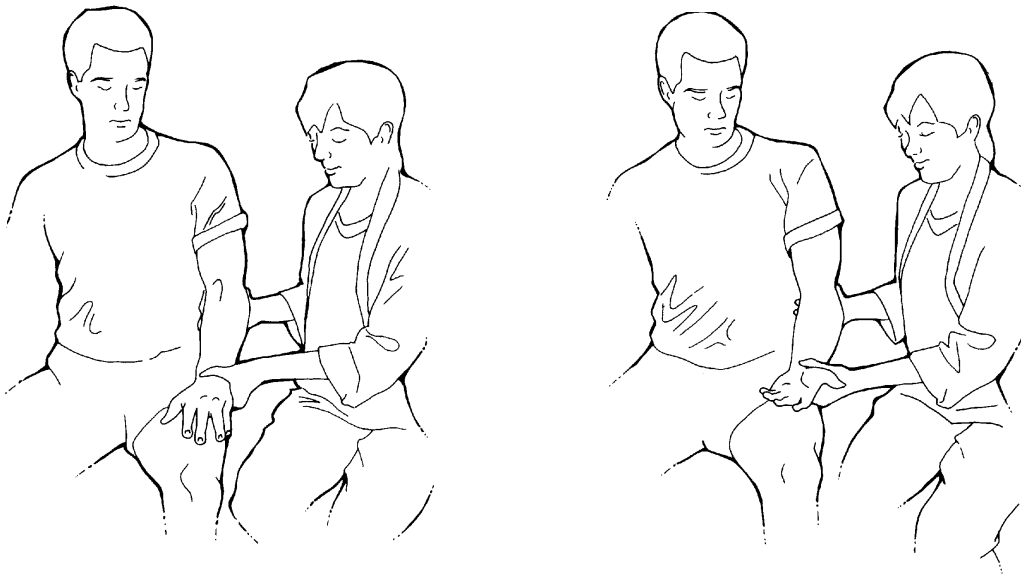

Wrist and Finger Flexion and Extension

As you bring your wrist back, bring your fingers in to make a fist. Then straighten out fingers as you bend the wrist down.

When the wrist is up, the fingers should remain bent. When the wrist is down, the fingers should remain straight.



Thumb

Bend and straighten thumb. Stretch thumb out to side to stretch "web space".

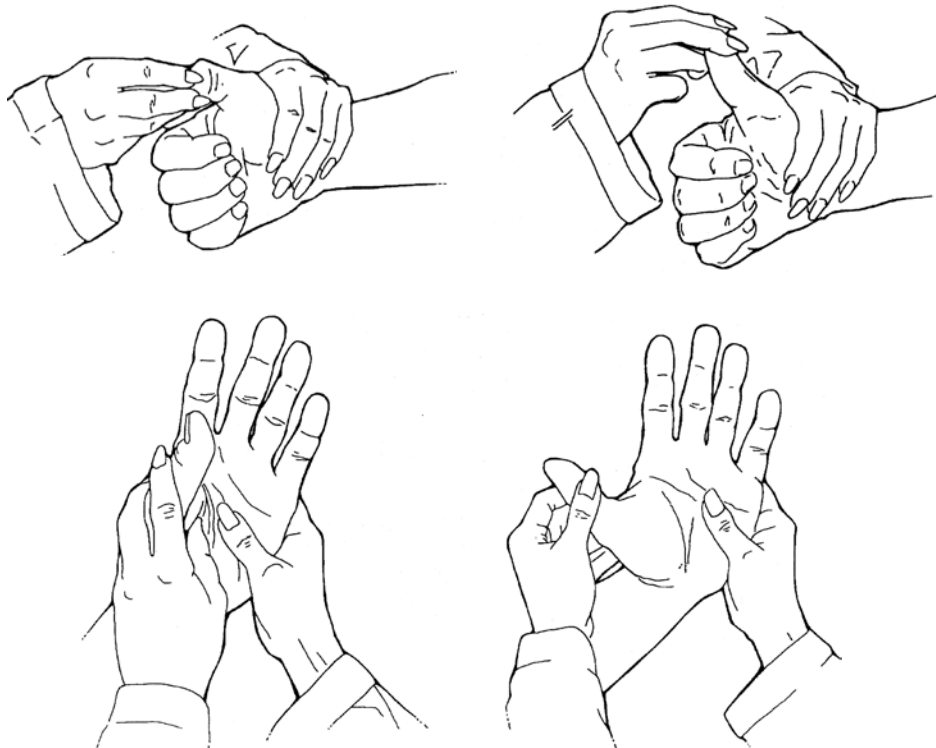

LOWER EXTREMITY PASSIVE RANGE OF MOTION EXERCISES

These exercises show someone else how to stretch your legs if you are unable to do this yourself. These exercises should be done slowly and gently. Each exercise can be done five times on each leg. If you have tightness in an area, hold the stretch longer (up to 30 seconds).

The following exercises are done while you are lying on your back.

Hip and Knee Flexion and Extension

One hand is placed under your knee and the other hand is placed under your heel. The knee is bent toward your chest with the kneecap pointed toward the ceiling. To get a good stretch, push the leg to the chest until there is minimal resistance. The leg is then lowered to the starting position.

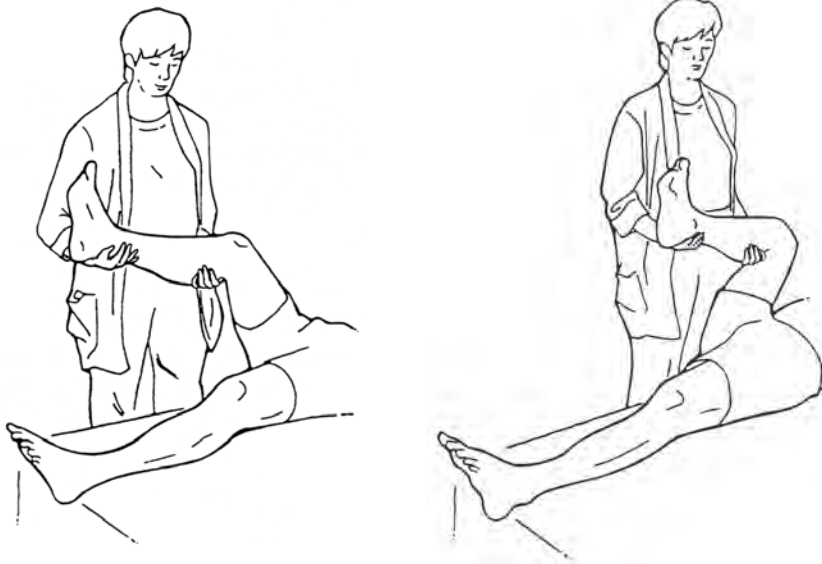

Hip Internal and External Rotation

Again, your knee is bent halfway to the chest so that there is a ninety degree angle at the hip and knee. One hand is placed on top of your knee and the other hand is placed under your heel. Your foot will then be pulled toward the person exercising you and then pushed away. Hold each position for 30 seconds or repeat five times slowly.

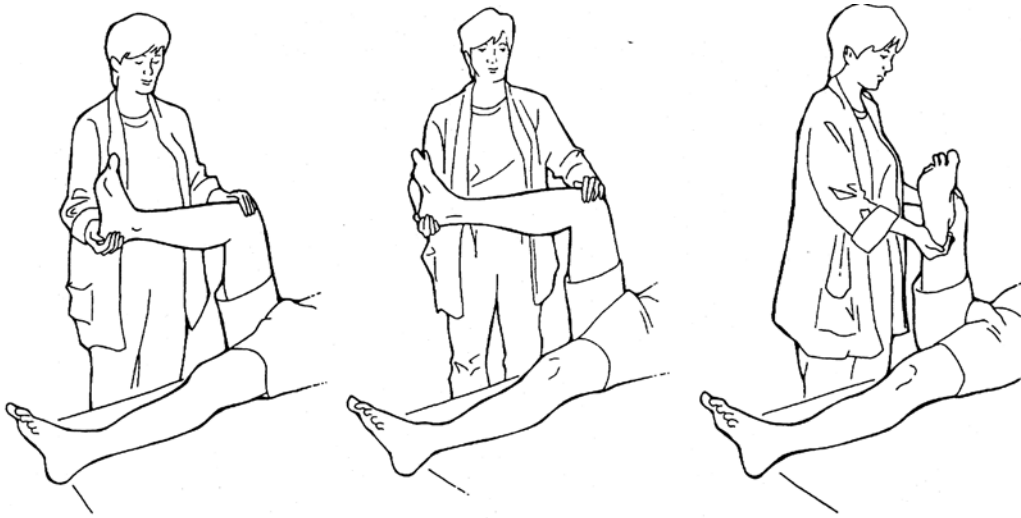

Hip Abduction and Adduction

One hand is placed under your knee and the other hand is placed under your heel. Keeping your knee straight, your whole leg will be pulled toward the person exercising you, with your kneecap pointed toward the ceiling. Your leg will then be brought back to your other leg. Hold for 30 seconds or repeat five times slowly.



Hamstring Stretching or Straight Leg Raises

Method No. 1

The person exercising you will kneel between your legs and will support your ankle with their arm or shoulder. Your knee will be straight. One or both hands will be placed just above your knee. If one hand is used, the other hand will be placed on the thigh of your other leg to keep it on the bed. If both hands are used, the person's knee may rest lightly on your other thigh.

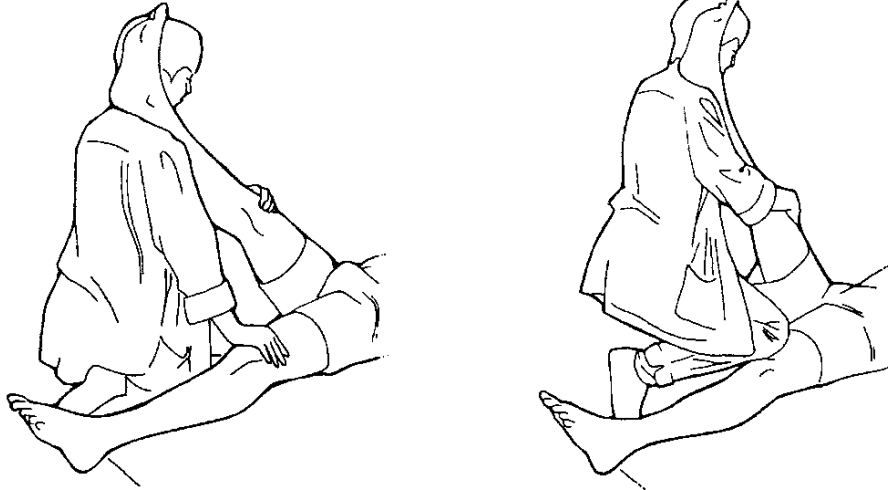

Method No. 2

One hand is placed under your knee and the other hand is placed under your heel. With your knee straight and your kneecap pointed toward the ceiling, your whole leg will be raised toward the ceiling. When your raised knee begins to bend slightly, the hand under your knee should be moved to the top of your knee. Hold for 30 seconds or repeat five times slowly.

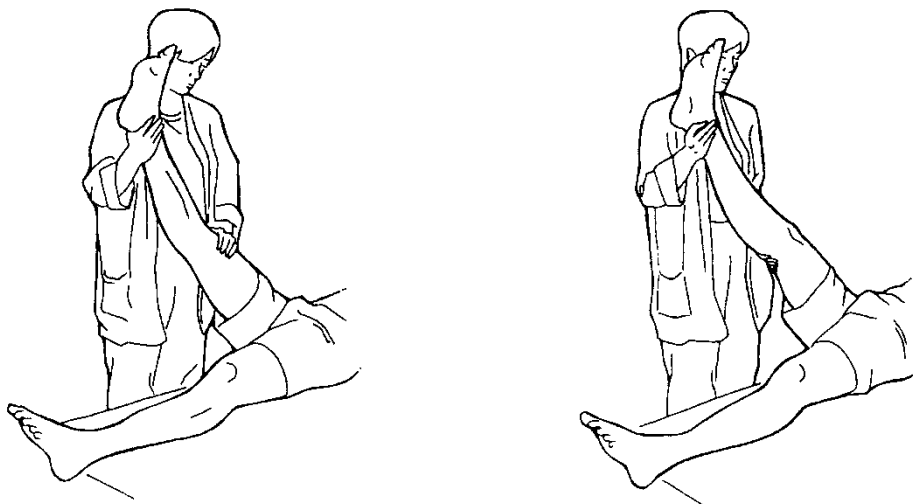

Heelcord Stretching

One hand cups the inside of your heel and the forearm is placed against the ball of your foot. The hand will pull down toward the foot of the bed and the forearm will press on the ball of your foot, bending your foot toward your knee.

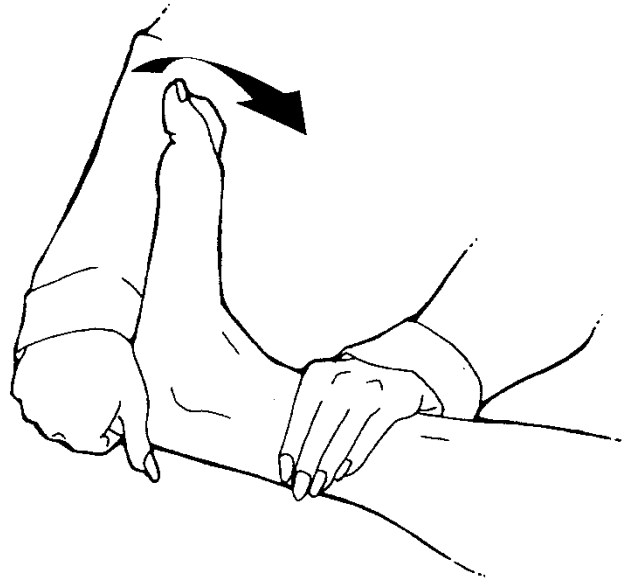

Foot Inversion and Eversion

One hand holds your foot near your heel and the other hand holds your lower leg near your ankle. Your foot is moved from side to side.

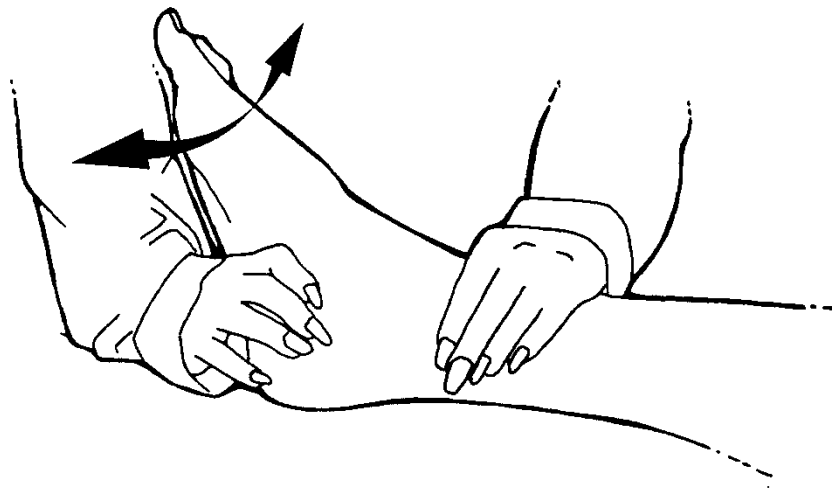

Toe Flexion and Extension

One hand stabilizes the foot just below the toes. The other gently moves each or all toes forward and backward. Hold for 30 seconds or repeat five times slowly.

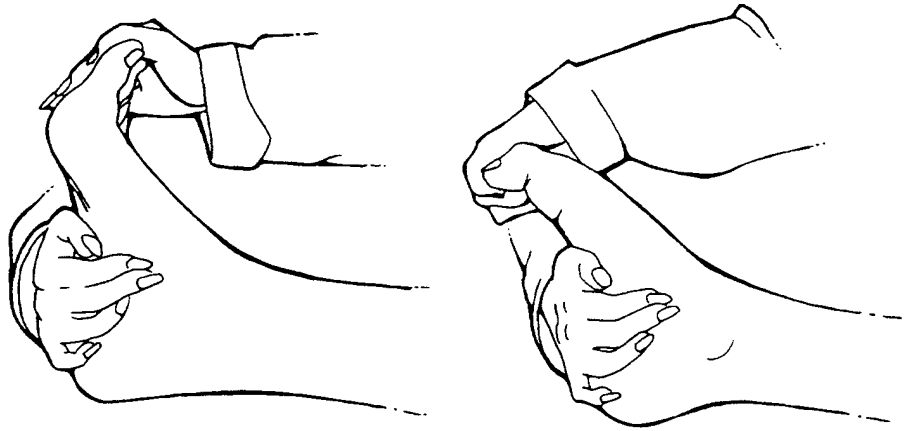

Hip Extension

This exercise is done while you are lying on your side. The person exercising you will be behind you. One hand is placed under your knee with your lower leg resting on the person's forearm. The other hand will hold your pelvis in place. Your leg will be pulled backwards toward the person exercising you. Hold for 30 seconds or repeat five times slowly.



Self-Stretching

What are some important points to remember?

1. NEVER use force when stretching. All that is required is enough force to allow the muscle to stretch.
2. Hold the position still, instead of bouncing, especially if you have spasms. This allows your muscle to relax and stretch.
3. A good time to do your stretching program is in the morning or in the evening as you do your skin inspection.

Self Range of Motion

Do these exercises leaning against the headboard of the bed, leaning against a piece of furniture that will not move or sitting in your wheelchair.

Hook your left wrist under the left knee. Pull left knee toward the chest. Hold for a count of 30 or repeat five times.



Sit with one knee bent toward chest. Use your hand to push the outside of the knee towards the other leg. Do not force. Hold for a count of 30 or repeat five times. Perform on each leg.

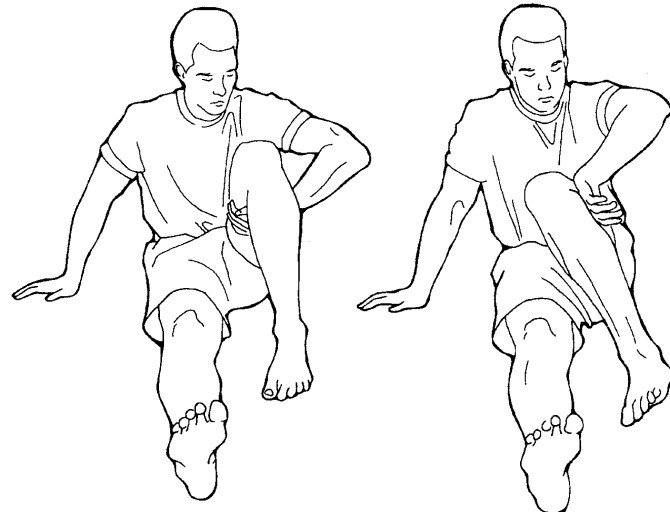

Sit with one knee bent up. Slowly lower it out to the side towards the mat or bed. Use your hand to push gently down against the inside of the knee. Do not force. Hold for a count of 30 or repeat five times. Repeat with other leg.



SECTION III

Method No. 1

Facing a bed or chair, place one leg straight out on the bed or chair and hold the knee straight. Do not lean forward as this will stretch you too much. Hold for three to five minutes on each leg.

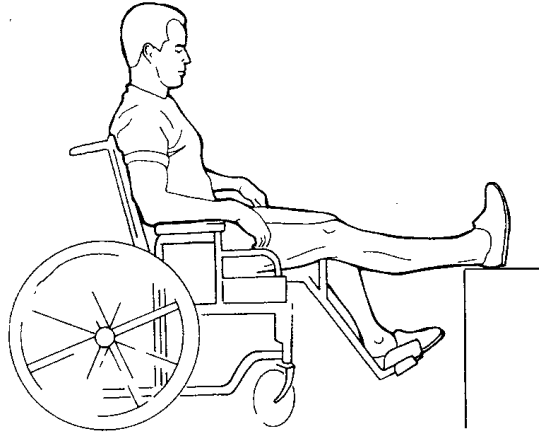

Method No. 2

Sitting at edge of bed, place one leg on floor and other leg along bed. Press knee down, but do not lean forward as this will stretch you too much. Hold for three to five minutes on each leg.

Sitting with legs stretched out in front, lean forward. You may use your elbows or hands to keep knees straight. Loop strap around the bottom of your foot. Pull towards you stretching the foot without turning to either side. Hold for a count of five. Repeat 10 times.

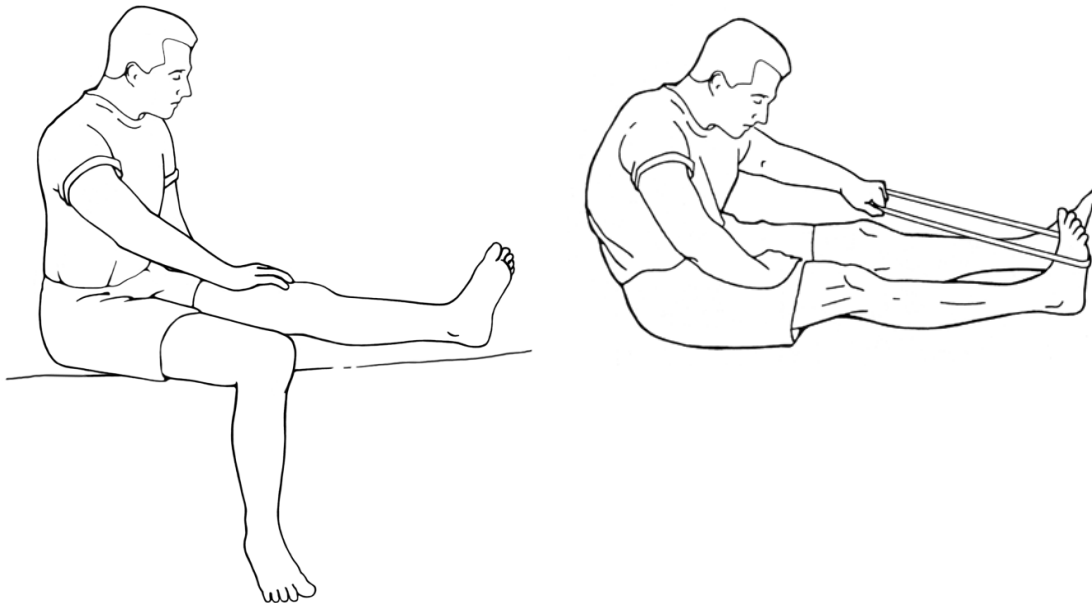

DRIVING

Following certain injuries or surgeries, returning to driving is not automatic and you must undergo a driving evaluation. To be eligible for a driving evaluation, you must have a physical or neurological impairment, have a valid driver's license or be eligible for one, and be 18 years or older (or 15 to 17 years old with parental consent). Referrals for this program are accepted from physicians, the DMV or by self-referral. A physician release is required for the program, along with a copy of your recent medical history.

The driving evaluation consists of two parts: a pre-driving assessment in the clinic and an on-the-road portion.

Your clinical evaluation will include an exam of the following:

- I. Complete History (Medications, Seizure History, Previous Driving History)
- II. Physical Assessment (Range of Motion, Strength, Tone, Sensation)
- III. Visual-Perceptual Evaluation (Visual Discrimination, Visual Sequential Memory)
- IV. Visual Testing (Visual Acuity, Traffic Color Recognition, Depth Perception)
- V. Cognition (Sign Recognition, Number Identification)
- VI. Reaction Time
- VII. Equipment Recommendations (Hand Controls, Spinner Knobs)

The staff at Carolinas Rehabilitation has more than 10 years of experience providing evaluations and developing compensations for a variety of physical, cognitive and emotional limitations. Carolinas Rehabilitation provides the pre-driving evaluation to determine your ability to drive after an injury or illness.

After the clinical evaluation has been performed, Carolinas Rehabilitation will gladly assist you in finding a specialist to perform an on-road evaluation within your community. Your certified driving instructor will teach you how to drive on quiet roads and eventually progress to highways and more complex driving situations using the adaptive devices that have been recommended for your specific deficits.

Possible results of the on-road evaluation consist of:

- I. Pass-Return to driving
- II. Defer Driving-Need some time for healing, rehabilitation or retraining
- III. Limited Driving-Continue to drive but with certain restrictions
- IV. On-The-Road Training-Recommend further training and practice time
- V. Fail-Unable to safely return to driving

Resources:

www.driver-ed.org

The Association for Driver Rehabilitation Specialists, (ADED) provides a website with information relating to how a spinal cord injury affects one's ability to drive.

www.aota.org/olderdriver

The American Occupational Therapy Association, (AOTA) provides a website with the ability to locate professionals with a Specialty Certification in Driving and Community Mobility (SCDCM) in your area. The website also provides a great deal of information regarding spinal cord injuries and driving.

www.nmeda.com

The National Mobility Equipment Dealers Association is an organization that sets standards for vendors who perform vehicle modifications. Their website can assist you to find qualified vendors within your community.

www.nmeda.com/quality-assurance-program

The Quality Assurance Program is the only nationally recognized accreditation program for the adaptive mobility equipment industry. To purchase vehicle modifications, look for NMEDA-QAP dealers to ensure standards that advocate the highest level of performance and safety.

Vehicle Modifications, Rent and Sale Locations

Ilderton Conversion Company

www.ildertonvans.com

5518 Westpark Drive
Charlotte, NC 28217
704-523-2022

Contact: Bobby Rolfes

701 S. Main St.
High Point, NC 27260
336-841-2020

Contact: Fisher Wood

1033 Wappoo Road
Charleston, SC 28407
843-576-0414

Contact: Joe Tuten

Carolina Mobility Sales

www.cmobilitysales.com

4025 Queen City Drive
Charlotte, NC 28208
704-837-1008

Contact: Jeff Stephens

3624 Fernandina Road
Columbia, SC 29210
803-791-7791

Contact: Tim Peterson

563 Woodruff Road
Greenville, SC 29607
864-599-9099

Enterprise and **Hertz** offer vehicle rental options that are wheelchair accessible with hand controls (advanced notification is required when making reservation)

Stalls Medical, Inc. /Adaptive Vans Inc.

www.stallsmedical.com

9908 Albemarle Road
Charlotte, NC 28227
704)-494-7222

5995-119 Chapel Hill Road
Raleigh, NC 27607
919-233-0732

6342A Burnt Poplar Road
Greensboro, NC 27409
336-294-1505

Van Products Inc.

www.vanproducts.com/

2521 Noblin Road
Raleigh, NC 27604
919-878-7110

394 North Green Meadows Drive
Wilmington, NC 28405
910-793-5661

Mountain Adaptive

www.mtnadaptive.com

35 Dogwood Road
Asheville, NC 28806
828-670-1111

Mobility Concepts Inc.

www.mobilityconcepts.org

65 Shiloh Road
Asheville, NC 28803
828-277-2577

Driver Evaluators and Trainers

Atlantic Physical Therapy and
Rehabilitation
www.atlanticphysicaltherapy.com
3650 Coalition Drive
Myrtle Beach, SC 28577
843-293-7713

Care Partners Health Services
www.carepartners.org
68 Sweeten Creek Road
Asheville, NC 28803
828-274-6179

Consolidated Driving School
www.consolidex.com
285 Wildwood Lane
Boone, NC 28607
828-264-3190

Driver Rehabilitation Services
www.driver-rehab.com
605 Cabaret Road
McLeansville, NC 27301
828-264-3190
Contact: Cyndee Crompton
or Brenda Kennell

Freedom and Mobility
www.freedomandmobility.com
1651 Canton Road
Marietta, GA 30066
770-514-9957

Frye Regional Medical Center
www.fryemedctr.com
420 North Center St.
Hickory, NC 28601
828-324-3712

Pitt County Memorial Hospital/
InRoads Driving Program
www.uhseast.com/rehab_driving
2100 Stantonsburg Road
P.O. Box 6028
Greenville, NC 27835-6028
252-847-6369

Shepherd Center
www.shepherd.org
2020 Peachtree Road N.W.
Atlanta, GA 30309
404-350-7720

EXAMPLES OF VEHICLE MODIFICATIONS

Hand Controls

Used to manage the gas and brake pedals.

Push/Rock - This unique rocking motion allows full-range braking and acceleration with minimal hand travel while keeping the hand in a neutral position. The driver eases the handle back to accelerate and pushes forward to brake. This option is accessible to drivers with limited finger dexterity.



Push/Right Angle - To operate the brake, push the handle upward, and to accelerate, push downward and to the right. This function is easily operated by drivers with limited finger dexterity.

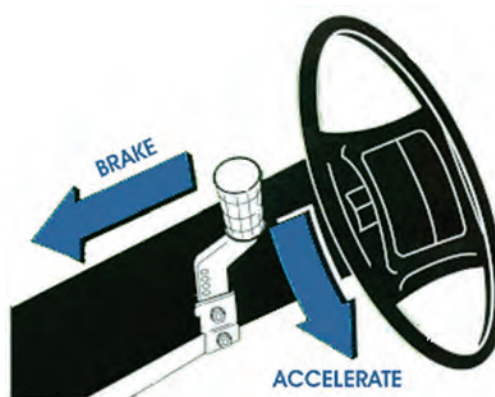

SECTION III

Push/Pull - Push forward on the handle to brake and pull the handle backwards to accelerate. This handle is easily operated by drivers with limited finger dexterity.



Push/Twist - Twist to accelerate and push the handle forward to brake (similar to a motorcycle handle). At least some finger dexterity is required for this hand control.



Electronic Mobility Controls - These are available at high cost and are extremely flexible in terms of the amount of movement needed, the strength required and the placement around the driver. Electronic controls provide amazing driving capability, even for people with serious disability.



SECTION III

Steering Wheel Attachments

Used to manage the steering wheel.

Spinner Knob - Simplifies driving, allowing for smooth, comfortable, one-handed use of the steering wheel. It is perfect for anyone with impaired hand function, or who needs to operate other driving controls with the other hand.



Single Pin - This is a great alternative to the spinner knob; for clients that cannot open their hand fully.



Steering Wheel Extension - For a driver who cannot operate a vehicle with a full-size wheel, this is an inexpensive and user-friendly solution. The size is customizable; consumers can select the diameter and height. It is also easily removable and compatible with most vehicle makes and models.



Palm Grip - For clients who do not require wrist support



SECTION III

Tri-Pin - Great for the independent driver with minimal gripping strength and/or reduced wrist stability.



Steering Wheel Attachment



Hand Control Attachment



Quad-Grip (Horizontal Tri-Pin)

V-Grip -For drivers with moderate gripping strength



Steering Wheel Attachment



Hand Control Attachment

Pedal Adaptations

Left Foot Gas Pedal - Acts exactly like your vehicle's existing gas pedal, just located on the left side of the brake pedal.



Gas Guard - Prevents accidental contact with the gas pedal from spasms.



Gas and Brake Guard - Prevents accidental contact with both brake and accelerator pedals.



Secondary Controls and Adaptations

Sure Switch - This directional control can operate your vehicle's exterior driving functions (blinkers, mirrors, lights) at the touch of a button.



Key Holders and Extensions - Provides better leverage and turning radius, and changes pinch and grasp required to utilize keys.



Horn Switch - Numerous options are available for controlling exterior driving functions (blinkers, mirrors, lights) depending on strength, range of motion and need.



SECTION III

Vehicle Lifts

Many factors will influence your decision when it comes to buying a wheelchair lift. A major consideration, of course, will be the type of wheelchair or scooter you are using. Vehicle accessibility for other passengers and multiple wheelchairs sharing the same vehicle are also important factors to consider. The type of vehicle you'll be using – whether a car, van or truck – will also impact the type of wheelchair lift that can be installed.

Under Vehicle Wheelchair Lift - An electric wheelchair lift that uses hydraulic power to operate, mounted underneath your vehicle allows for full window view and greater interior space



Folding Lifts - Unfolds at the touch of a button, can be installed for side or rear entry. Internally mounted, with single or dual hydraulic lift arms.



Internal Platform Lifts - Lifts and internally stores an unoccupied wheelchair.



SECTION III

Exterior Platform Lifts - Lifts and stores an unoccupied wheelchair externally.



Ramps - Internally mounted wheelchair ramp expands at the push of a button (portable-manual style available). May be mounted for rear or side access.



Crane/Hoist - Lifts and stores most rigid frame or foldable manual chairs behind the driver's seat.



SECTION III

Car-Top Carrier - For standard folding wheelchairs, automatically folds and stores into a weather-resistant car-top compartment.



Truck Crane/Hoist - Lifts and stores most rigid or foldable manual chairs into the bed of truck.



Internal Swivel Seats - Automatically slides back, rotates, and raises and lowers for ease of transfer into the driver or passenger seat from wheelchair.



SECTION III

Swivel Seats - Rotates out and bridges the gap allowing for safer transfers.



Seat Lifts - Seat automatically rotates out of vehicle and lowers downward towards the ground allows for safer transfers and access into higher vehicles.



SECTION III

Wheelchair Tie Downs

Q-Strait M-Series - Economical option for manual wheelchair strap restraint system.



Q-Strait Deluxe - Self-locking, self-tensioning retractable strap system allowing securing of both manual and power wheelchairs.



EZ Lock - Docking system that is a versatile, reliable and safe alternative to fabric strap tie downs.



Options for Financial Assistance

Typically, most insurance companies cover the cost of the pre-driving assessment that takes place in the clinic; however they do not cover the cost of the on-road evaluation. Also, most insurance companies do not pay for adaptive equipment for driving, but financial options may be available to you. The cost of the adaptive equipment for driving varies tremendously depending on the equipment needed.

Some automotive manufacturers offer mobility programs in which adaptive equipment items are eligible for reimbursement for up to \$1,200. Companies that have such programs include GM, Saturn, Ford, Jaguar, Volkswagen, Volvo, Chrysler, Toyota and Lexus. These programs were established to provide cash payments to disabled drivers for the installation of adaptive equipment. Be sure to check with your vehicle's manufacturer for possible programs or incentives.

There are also many organizations that provide financial assistance for your wheelchair accessible vehicle. Government programs are available such as the Department of Disability and Special Needs, Veterans Administration, Independent Living, and Vocational Rehabilitation.

Obtaining Handicap Plates and Parking Placards

The North Carolina Division of Motor Vehicles provides three types of handicap licensing:

- I. Five-year handicap parking placard (\$5 per placard, limit two per person)
- II. Temporary (up to six months) handicap parking placard
- III. Handicap driver registration plate/tag (\$28 handicap license plate fee)

Your doctor must certify to NCDMV that you have mobility impairment (unable to walk without an assistive device or cannot walk 200 feet without stopping to rest). Only the individual who is issued the placard or plate may use handicap parking privileges. The handicap parking placard/tags may only be used when the person who was issued the placard or plate is in the vehicle. If that person is not in the car, the driver may not use handicap parking for any purpose.

A temporary placard is not renewable while the five-year placard may only be renewed with the recertification of a physician. Handicap plates/tags must be renewed by sticker annually and recertified by your physician every five years.

You may obtain an application form for a handicap parking placard/tag from any DMV license plate agency, or download one at:

www.ncdot.gov/dmv/vehicle/plates/handicapped

While a patient at Carolinas Rehabilitation, your social worker may assist you with the application process for handicap parking placard/tags.

SECTION III

MVR-37 (Rev. 2/08)



NORTH CAROLINA
 DIVISION OF MOTOR VEHICLES
 3148 Mail Service Center
 Raleigh, NC 27699-3148

Do not write in this space

APPLICATION FOR HANDICAPPED DRIVERS REGISTRATION PLATE

VEHICLE SECTION				
YEAR	MAKE	BODY STYLE	SERIES MODEL	VEHICLE IDENTIFICATION NUMBER

OWNER SECTION	
Owner 1 ID # _____	Full Legal Name of Owner 1 (First, Middle, Last, Suffix) or Company Name _____
Residence Address (Individual) Business Address (Firm) _____	
City and State _____	
Mail Address (if different from above) _____	
<i>I certify for the motor vehicle described above that I have financial responsibility as required by law.</i>	
_____ Insurance company authorized in NC	_____ Policy Number

(This application must be signed by your physician)		Year _____
<p>G.S. 20-37.5 Handicapped – definitions and parking privileges. (1) "Handicapped" shall mean a person with a mobility impairment who, as determined by a licensed physician; (a) Cannot walk 200 feet without stopping to rest; (b) Cannot walk without the use of, or assistance from, a brace, cane, crutch, another person, prosthetic device, wheelchair, or other assistive device; (c) Is restricted by lung disease to such an extent that the person's forced (respiratory) expiratory volume of one second, when measured by spirometry, is less than one liter, or the arterial oxygen tension is less than 60 mm/hg on room air at rest; (d) Uses portable oxygen; (e) Has a cardiac condition to the extent that the person's functional limitations are classified in severity as Class III or Class IV according to standards set by the American Heart Association; (f) Is severely limited in their ability to walk due to an arthritic, neurological, or orthopedic condition; or (g) Is totally blind or whose vision with glasses is so defective as to prevent the performance of ordinary activity for which eyesight is essential, as certified by a licensed ophthalmologist, optometrist, or the Division of Services for the Blind.</p> <p>Any person who falls within the definition of handicapped shall be allowed to park for unlimited periods in parking zones restricted as to length of time parking is permitted. This provision has no application to those zones or during times in which the stopping, parking, or standing of all vehicles is prohibited or which are reserved for special types of vehicles. As a condition to this privilege the vehicle shall display a distinguishing license plate or removable windshield placard.</p> <p>I hereby apply for a handicapped drivers registration plate under the above statutory provisions and certify that my physical condition entitles me to the issuance thereof.</p>		
_____ (Applicant's Signature)	_____ (Date)	
I hereby certify that the physical condition of the above named applicant constitutes the applicant a handicapped driver as defined under statutory provision G.S. 20-37.5 and G.S. 20-37.6.		
_____ (Physician's Signature)	_____ (Physician's Printed Name)	_____ (Date)
_____ (Physician's Address)	_____ (Physician's Telephone Number)	
<i>(These plates are issued from Raleigh Office only)</i>		
FEE: REGULAR REGISTRATION PLATE FEE		

RECREATION

“Surviving is important. Thriving is elegant.”

~Maya Angelou

When most people hear the word “recreation” they think of softball, basketball, football and other sports, but the word encompasses so much more! Recreation is anything and everything we do simply because we enjoy it. What sorts of things do you enjoy doing? Do you like going to the movies or out to eat with your friends? Do you enjoy reading or working on a computer? Do you like playing chess, a musical instrument or even video games? All of these and so much more fall under the category of recreation and, with a little tweaking, can be enjoyed by everyone.

Recreation is not only a way to have fun. It is a way to stay physically fit. It is a way to meet new people who have gone through or are going through the same sort of things you are. It is a way to gain independence in an activity that you enjoy and, hopefully, transfer that over into greater independence in life.

So where do we even begin? Which activities do you want to pursue? What types of things are out there that you might want to try? Where can you find information on adapted recreation or adapted equipment? These are some of the general questions we will try to answer in this section of your SCI education book. Your recreation therapist has additional handouts that cover recreation topics more specific to you.

Carolinas Rehabilitation offers a community program call the Adaptive Sports and Adventures Program (ASAP). Most of our peer volunteers are extremely active in this program. We offer all sorts of programs, such as fishing, rugby, soccer, kayaking, hand-cycling, tennis, waterskiing, snow skiing, golf. There is more information on ASAP later on in this section. We encourage you to fill out the information sheet so that we can keep you up-to-date with what is going on at ASAP. You can give it to one of your therapists or send it in using the prepaid envelope in your SCI education book.

If you have any questions while you are here or after you leave Carolinas Rehabilitation, please feel free to call the Recreational Therapy Department. Whether you have questions about where to find a specific activity near where you live or how to adapt a recreation or leisure activity, we are more than happy to be of service. Thanks for choosing Carolinas Rehabilitation and we hope to see you at one of our many excellent Adaptive Sports and Adventures Program. Feel free to check out our website for our latest newsletter and calendar.

SECTION III

2012 ASAP Participation/ Volunteer Form

Carolinas Rehabilitation

Therapeutic Recreation – Adaptive Sports and Adventures Program

CarolinasHealthCare.org/ASAP

Inpatient: 704-355-4464

Adaptive Sports and Adventures Program: 704-355-1062

On behalf of the staff of the Adaptive Sports and Adventures Program (ASAP), I welcome you to many new and exciting opportunities that you will now have access to. When you fill out this form, we will be able to notify you of the various opportunities provided to people of all ages and abilities by and through ASAP. It is our goal to continue to provide these opportunities, create new ones, and establish new contacts and resources to provide you with all the competitive and recreational opportunities possible.

<input type="checkbox"/> Participant	<input type="checkbox"/> Volunteer	
Name: _____ DOB: _____		
Guardian (if applicable): _____		
Emergency Contact Name: _____ Cell: _____		
Address: _____		
City: _____ State: _____ Zip: _____		
Home Phone: _____ Cell: _____		
Email Address: _____		
If applicable: Disability/Level of Injury: _____		
Other Medical Conditions: _____		
Please Check Program(s) of Interest		
Team Sports:	Clubs/Groups:	
<input type="checkbox"/> Wheelchair Rugby	<input type="checkbox"/> Winners on Wheels (WOW)	
<input type="checkbox"/> Power Soccer	<input type="checkbox"/> SCI Social/Support Group	
<input type="checkbox"/> Water ski	<input type="checkbox"/> Brain Injury Support Group	
Outdoor Recreation/Adventures:		
<input type="checkbox"/> Snow Skiing	<input type="checkbox"/> Swimming (youth)	<input type="checkbox"/> Tennis
<input type="checkbox"/> Water Skiing	<input type="checkbox"/> Kayaking (adult)	<input type="checkbox"/> Fishing
<input type="checkbox"/> Cycling	<input type="checkbox"/> Golf	<input type="checkbox"/> Other (please explain)
Waiver: In consideration of my or my child's participation in Adaptive Sports & Adventures Program (ASAP) events and programs, I release and hold harmless the Carolinas Healthcare System d/b/a Carolinas Rehabilitation and any and all employees or agents, to the extent allowed by law for any injuries resulting from my or my child's participation in such activities. I have informed the ASAP staff of any physical or medical conditions that may hinder my or my child's participation in the program or activity. Furthermore, unless stated in writing, I give my permission to use any photographs taken in programs or services for public relations purposes, understanding all confidential information will be upheld.		
Participant's Signature: _____		Date: _____
Parent's Signature (if participant is under age 18) _____		

Useful Website Resources

Spinal Cord Injury Resources

nccpad.org - National Center on Physical Activity and Disability

paralysis.org - Paralysis Resources

spinalcord.org - National Spinal Cord Injury Association

General Resources

disaboom.com - Living Forward

pva.org - Paralyzed Veterans Association

icdri.org - International Center for Disability Resources

disabilityinfor.org - Resources for Americans with disability

disabilityonline.org - Disability Information Directory

Sports, Activities and More

Pvomagazines.com/sns - Sports 'n Spokes

Adaptiveoutdoorsman.com - Adaptive Hunter, Fishing and Camping Equipment

Blazesports.com - Blaze Sports of America

Quadrugby.com - United States Quad Rugby Association

Nwtf.org - National Wild Turkey Federation, Hunting

Kripplekreek.com - Tree stand technology for hunting

Charlotttrackandtriclub.org - Charlotte Track and Triathlon Club

Powersoccerusa.net - United States Power Soccer Association

Paralympic.org - International Paralympic Committee

Challengedathletes.org - Challenged Athletes Foundation

Carolinacrash.org - quad rugby team, sponsored by CMC/ASAP

Teambambur.com - Adaptive snow skiing

Nwpainc.org - National Poolplayer Wheelchair Association

Bike-on.com - Handcycles

Freedomsings.org - Adaptive Flying of Airplanes

Wheelchair-bodybuilding.com - Wheelchair Body Building

Wheelchairdancesportusa.com - Wheelchair dancing

Awba.com - American Bowling Association

Sitki.com - Extreme sports

Living Forward

Icanonline.net - Leading disability community

Recreation Equipment

Accesstr.com - Access to recreation

Sportaid.com - Wheelchairs, handcycles, cool wheels and stuff

Beadaptive.com - Adaptive equipment (hunting, etc)

Assistive Technology

Broadenedhorizons.com

Infinite.org - Infinite potential thru assistive technology

Abledata.com

Assistivetechologies.com

SECTION III

Wheelchairs and Accessories

Thewheelchairsite.com/wheelchair-accessories.aspx

Colourswheelchair.com - Colours in Motion

Newdisability.com

Wheelchairgear.com

Fashion, Women/Men's Clothing

Wheeliexchic.com - women's clothing

Beautyability.com - adapting fashion to your wheelchair

Rolli-moden.com - men's clothing

Tallgirlshop.com - longer length women's clothing

Wheelchairjeans.com - better fitting jeans for wheelchair

Professionalfit.com - adaptive clothing solutions

Humor, Disability T-shirts and Accessories

Cafepress.com/disabilities

Cafepress.com/handicapped

Cafepress.com/wheelchair

Cafepress.com/spinal-cord-injury

Zazzle.com/handicapped

Other

Broadenedhorizons.com - technology

Scholarships

Chairscholars.org - Wheelchair Success Foundation

For Caregivers

Nfcacares.org - National Caregivers Association

Magazines

Pvomagazines.com/sns - Sports 'n Spokes

Sportaid.com

Newmobility.com

Pn-magazine.com - Paraplegia News

Disableddealer.com - Disabled Dealer

Activelivingmagazine.com - The Adapted Lifestyle Resource Guide

Disability Laws

Access-board.gov/gs.htm - United States Access Board

Self-Defense

Defenseability.com - International Disabled Self-Defense Association

One

SECTION IV

SEXUALITY FOR MEN

Can I still have an erection?

Depending on your injury, there is almost always a way to achieve an erection, although doing so may be different than before. Specifics need to be discussed with your physician (your urologist or physiatrist), but here are **some** general guidelines.

If the injury is in the neck (cervical area) or upper part of the spinal cord (thoracic area), most men find they can achieve an erection by direct stimulation to the genital area (reflexogenic). This means just thinking about sex won't necessarily give you an erection. If your injury is below L2, you may achieve an erection from physical stimulation and will likely experience at least a partial erection from psychogenic (mental) influences such as thoughts, memories or fantasies. For any spinal cord injury, you may find it more difficult to get and maintain an erection than it was before your injury.

If I cannot have an erection, what can I do?

There are techniques and a number of devices available to help you get and keep an erection for intercourse. These may range from taking a pill or direct application of medicine, to an injection or the use of an external negative pressure device. See your physician or the Continence Center/Urology at Carolinas Rehabilitation in Charlotte to discuss the best options for you and your partner. It's important to include your partner in the decision-making process. You may find an erection is not necessary and that other alternative sexual techniques are just as pleasurable.

What if I can get an erection but cannot ejaculate?

People often consider orgasm and ejaculation to be one and the same. In fact, orgasm and ejaculation do not even always occur simultaneously in non-injured men. Orgasm happens in the brain and should be enjoyed with or without ejaculation. (Note: If you are concerned about fathering children, this will be addressed later in this chapter.)

Will sex be harmful to me?

Sexual activity should be safe, but there are several factors that should be considered. If your injury is at the T6 level or above, you should be aware of autonomic dysreflexia (see dysreflexia chapter) and take the necessary precautions. If you have an indwelling catheter, you will want to prevent pulling on the bladder/urethra by wearing a condom over the penis and catheter and using plenty of lubrication. If you are on medications, consult your physician, because some medications affect sex drive.

Issues such as positioning may require some experimentation between you and your partner, but your therapists can offer advice and illustrations. It is important to try a variety of techniques and positions in order to find out what is most pleasurable and comfortable for you and your partner. The process of rediscovering sexuality after spinal cord injury requires adjustment, patience and a gradual understanding of important new information. Communication is essential for both partners to grow together in their new experience. It is especially important to seek answers to the many questions and concerns that may arise. Don't be afraid to talk about your sexuality. Even though you may feel uncomfortable, it is an important part of life.

What kind of sex life will I have?

Initiating intimacy may feel somewhat awkward. It will take time to learn what your partner can do to give you pleasure, as well as what you can do to give your partner pleasure. At first, concentrate on the process of giving and receiving. Enjoy finding out what you are able to do physically to provide pleasure to your partner, and don't be afraid to try different things.

There are also options for you and your partner to discover and develop other sensual areas of your body, called erogenous zones (especially where you still have sensation). By using visual, tactile or fantasy stimulation, you may be able to heighten your sexual experience. This may take some time to develop, but just as before your injury, it's important to work on mutual satisfaction between you and your partner. You also need to remember there are many ways of providing pleasure for your partner. These ways are limited only by your imagination, physical ability and what you both believe is appropriate sexual behavior.

What about bowel or bladder accidents?

It is important for your partner to be aware that bowel and bladder accidents are possible during intimacy. Explaining bowel and bladder issues can be difficult, but it's important for your partner to know about this possibility. Most couples who know of the potential for an accident keep a towel handy to clean up and quickly resume intimacy.

One way to reduce the chance of having a bladder accident is to cut back on fluids three to four hours prior to sexual activity and empty your bladder immediately before. If you have an indwelling catheter, you also have the option of folding the catheter over your penis and placing a condom over both to keep the catheter in place (this may also help sustain an erection). You may want to perform your bowel program prior to sexual activity as well, to avoid a bowel accident.

How will I ever establish new romantic relationships?

It's important to continue socializing, even after spinal cord injury. Think about where you are most comfortable meeting people, such as at work, school, church groups, support groups and other social events. Try volunteering or joining a singles group. Some people may experience discomfort with your disability but are willing to overcome this in getting to know you as a person. Unfortunately, you will most likely need to take the responsibility to put able-bodied people at ease, so you can get to know each other.

When you do establish a relationship that leads to intimacy, discussing sex can be difficult. Your initial reaction may be to try to hide or put off explaining that you have a catheter or leg bag, that you don't have full control over your bladder or possibly your bowels. It is far easier in the long run to explain things as a matter of fact earlier in the relationship, as you discuss your injury. You will find the non-disabled population, in general, has a much more open attitude about dealing with these issues than you might expect.

Will my partner stay with me after my injury?

Statistics show that men who are married at the time of injury have no greater divorce rate than non-injured men. Interestingly enough, spinal cord injured men who are married after their injury have a greater chance of staying married than able-bodied men in the general population.

Communication is a key factor. If you and your partner were able to communicate well prior to the injury, and deal with problems successfully – whether they were financial, sexual, family, in-laws, children, etc. – you will probably be able to deal with this new situation.

Couples that were having difficulty prior to the injury are more vulnerable. In this case, you may need to work on opening up with your partner and developing good communication. You can get help from counselors, social workers and psychologists at Carolinas Rehabilitation in Charlotte or in your community.

Can I have children?

While some of the fertility issues for males with spinal cord injury are similar to other fertility problems, a main concern is the ability to ejaculate – to get the sperm out. Much of the current research is focused on assisting ejaculation. There are many new techniques, including electro-ejaculation and vibration techniques, which enable a spinal cord-injured man, who is unable to ejaculate, to father children. For more information, discuss this further with your SCI physician or the urology clinic at Carolinas Rehabilitation.

Many of the tips for fertility are basically the same as for the general population: maintain good health through nutrition, regular exercise, good sleep habits, and minimum of caffeine and medications. The urology clinic can also provide more specific guidelines for the spinal cord-injured male. Our clinic has been able to help others become parents and will be ready to help you, too.

What kind of father will I be?

If they are not able to participate in traditional fatherly roles, such as sports and outdoor activities, some men feel their relationships with their children will suffer. Although there are some recreational and child care activities that will be more difficult with your injury, there are many leisure activities that can be shared with your able-bodied children and spouse. Nursing/babysitting care may need to be sought, and some of the responsibilities may need to be shared with your partner, but many child care chores can be done by most spinal cord-injured people. Most important, your ability to be a good father is not tied to your physical function and, like other relationships, will be closely linked to open communication, mutual respect and love. Discuss sports and recreational interests, as well as community resources, with your recreational therapist.

SEXUALITY FOR WOMEN

Can I still enjoy sexual activity, now that I've had a spinal cord injury?

Your disability has changed many aspects of your life, perhaps including your ability for sexual expression, but you can continue to give and receive sexual pleasure. Remember that being a sexual person involves more than just genital stimulation. All of your senses can provide sexual stimulation. Many people have discovered a renewed pleasure in exploring and stimulating other erogenous zones. Intercourse, along with other types of sexual expression, can continue to be enjoyable.

Will sex be harmful to me, and are there any special precautions I need to take?

Sexual activity should be safe, but there are several factors to consider. If your injury is at the T6 level or above, you should be aware of autonomic dyreflexia (see dyreflexia chapter) and take the necessary precautions. If you are on medications, consult your physician, because some medications can affect sex drive.

Issues such as positioning may require experimentation by you and your partner, but your therapists may be able to offer advice and illustrations. It's important to try a variety of techniques and positions in order to find out what is most pleasurable and comfortable for you and your partner. The process of re-discovering sexuality after spinal cord injury requires adjustment, patience and a gradual understanding of important new information. Communication is essential for both partners to grow together in their new experience. It is especially important to seek answers to the many questions and concerns that may arise. Don't be afraid to talk about your sexuality. Even though you may feel uncomfortable, it is an important part of life.

You may notice a decrease in vaginal lubrication and may find it helpful to use a water-based or water soluble lubricant, such as KY Jelly or Astrolube. This will protect your delicate skin and may enhance your partner's pleasure. Vaseline should not be used as a lubricant, as its use may put you at risk for bacterial infections.

Will my relationship with my partner be affected? Will my partner stay with me?

Communication is a key in any relationship. If you and your partner were able to communicate well prior to the injury and deal with problems successfully – whether they were financial, sexual, family, in-laws, children, etc. – you will probably be able to deal with this new situation.

Couples that were having difficulty prior to the injury are more vulnerable. In this case you may need to work on opening up with your partner and developing good communication. You can get help from counselors, social workers, and psychologists at Carolinas Rehabilitation or in your community to help the two of you.

How will I ever establish new romantic relationships?

It's important to continue socializing, even after spinal cord injury. Think about where you are most comfortable meeting people, such as at work, school, church groups, support groups and other social events. Try volunteering or joining a singles group. Some people may experience discomfort with your disability but are willing to overcome this in getting to know you as a person. Unfortunately, you will most likely need to take the responsibility to put able-bodied people at ease, so you can get to know each other.

When you do establish a relationship that leads to intimacy, discussing sex can be difficult. Your initial reaction may be to try to hide or put off explaining that you have a catheter or leg bag, or that you don't have full control over your bladder and possibly your bowels. It is far easier in the long run to explain things as a matter of fact earlier in the relationship, as you discuss your injury. You will find the non-disabled population, in general, has a much more open attitude about dealing with these issues than you might expect.

What kind of sex life will I have?

Getting a sex life started may feel somewhat awkward. It will take time to learn what your partner can do to give you pleasure, as well as what you can do to give your partner pleasure. At first, concentrate on the process of giving and receiving. Enjoy finding out what you are able to do physically to provide pleasure to your partner, and don't be afraid to try different things.

There are also options for you and your partner to discover and develop other sensual areas of the body, called erogenous zones (especially where you still have sensation). By using visual, tactile or fantasy stimulation, you may be able to heighten your sexual experience. This may take some time to develop, but just as before your injury, it is important to work on mutual satisfaction between you and your partner. You also need to remember that there are many ways of providing pleasure for your partner. These ways are limited only by your imagination, physical ability and what you both believe is appropriate sexual behavior.

Can I still experience orgasm?

Many patients with spinal cord injuries report a pleasurable awareness of increased blood pressure, heart rate, tingling and relaxation. Your thoughts and sexual fantasies play a large part in a successful sex life. Although orgasm may be somewhat different, recent research suggests more than half of women experience orgasm after a spinal cord injury. Remember, you can have a rewarding sex life with or without orgasm.

What should I do about catheters, spasms, and bowel or bladder accidents during intimate moments?

The physical changes you experience after a spinal cord injury require you to plan in advance for many activities in your life. This is especially true for sexual activity.

Considerations for Bladder Management

- To prevent urinary accidents, decrease your fluid intake three to four hours before sexual activity.
- If you are on a catheterization program, empty your bladder before sexual activity.
- People using an indwelling catheter have several options:
 - a. Remove the catheter. The amount of time the catheter can be out of the bladder needs to be discussed with your doctor. If you cannot replace the catheter, a person that is able to replace it needs to be available. This is very important if you are prone to autonomic dysreflexia.
 - b. Do not remove catheter. You may tape the tubing to your stomach or thigh.

Considerations for Bowel Management

- To prevent a bowel accident, plan to do a bowel routine that morning or evening or just before sexual activity. If your bowels are not empty, sexual activity may trigger the bowel reflex. Be sure your partner is aware of the possibility of an accident. You may even want to have a towel handy so clean up will be easy and intimacy can be quickly resumed.

Considerations for Spasticity Management

- As spasms may interfere with transfers and bed mobility, they may also interfere with sexual activity. However, you may be able to use spasticity to heighten your sexual activity. If you have any questions, speak with your SCI nursing staff, urology nursing staff or psychologist.

Medications

Some medications prescribed may interfere with sexual function. Always consult with your doctor for more information.

Will I have a menstrual cycle?

There may be a temporary interruption in your regular monthly periods, due to the physical and emotional stress of the injury. However, many women don't miss even one period. If you haven't had a period six months after your injury, talk with your doctor.

When your periods do occur

- a. You may continue to use the same protection (tampons or pads) that you used before the injury.
- b. If you have a problem taking care of this by yourself, be sure to talk to your therapist for adaptive techniques to increase your independence with care.
- c. If you had menstrual cramps before your injury, you may or may not continue to have them afterward.

Can I get pregnant?

While a man's fertility can be greatly affected by spinal cord injury, a woman's ability to conceive is unchanged. A lot of women with spinal cord injuries have the misconception that they can't get pregnant. They may assume that if their legs aren't moving, nothing below the waist is "working." The possibility that menstruation may stop for up to six months following injury adds to the belief that spinal cord injury, itself, is a form of birth control. The reality is this: If a woman could conceive (get pregnant) before injury, she can conceive after injury.

What type of birth control should I use?

There are pros and cons to all birth control methods, however some may have more risks now that you have a spinal cord injury. Birth control options should be discussed with your physician.

Are there risks of birth defects?

In general, you have no greater chance of having children with birth defects as a spinal cord-injured female than you did before injury. During pregnancy it is important to maintain good health through good nutrition, sleeping, minimizing coffee and tobacco intake, minimizing medication intake, and staying away from drug and alcohol use.

Will I be able to carry the baby to term?

If you are healthy and have no other problems that might affect your pregnancy, a spinal cord injury is unlikely to affect your ability to carry a baby to term. Some spinal cord-injured women, however, do go into labor prematurely. Should you do so, the doctor may administer medications that will stop labor without harming the fetus. On the other hand, if your baby is well developed – and your pregnancy has passed the 32nd week – the doctor may go ahead with the delivery. In order to be prepared for either occurrence, be sure to discuss the possibilities and options with your obstetrician in advance of your due date.

How will I find an obstetrician that can care for both my pregnancy and spinal cord injury?

Since there are special considerations that govern the care of pregnant women with spinal cord injury, ask your primary spinal cord injury physician for recommendations. You may also ask your physician for names of women that are spinal cord injured to contact for an obstetrician recommendation. Your family doctor might also be helpful.

What if the obstetrician lacks experience caring for women with spinal cord injury?

Since each spinal cord injury is unique, you cannot expect your obstetrician to have all the answers. You can, however, expect him or her to be willing to learn and be open to suggestions. Since you will be the best resource your doctor has, he or she should be willing to listen to you. If you feel the doctor is not listening or has some preconceived ideas that might affect your care adversely, feel free to seek another physician.

Will my spinal cord injury create problems for me during pregnancy?

Many pregnant women experience swelling (edema) of their legs and feet, but women with spinal cord injury usually experience even more swelling than normal. You may also find that transfers, as well as general mobility, are more difficult because of increased weight gain and change in your center of gravity. Bladder complications may occur, including incontinence or urinary tract infections. You may also experience general fatigue, not only from being pregnant, but from having to carry additional weight. Risk for pressure sores may also increase. It will be very important to remind yourself to perform pressure relief/weight shifts every half-hour.

Do medications affect pregnancy?

Many medications can affect pregnancy. Check with your doctor about possible side effects of any medication you are taking, even over-the-counter remedies. Some antibiotics, as well as medications you might take for bladder control, are safe and are generally risk free. Again, do not take either prescribed or over-the-counter medication without first consulting your doctor.

Is it possible for a woman with spinal cord injury to have a vaginal delivery, or will I have to have a C-section?

You should be able to have a normal vaginal delivery, unless you have gynecological problems unrelated to your spinal cord injury. Your delivery may be easier and faster than it would have been otherwise, due to the loss of sensation and muscle tone changes that occur after a spinal cord injury.

Many people, including physicians, believe women with spinal cord injury should have a C-section. The reality is women with spinal cord injury have no greater need for a C-section than an able-bodied woman. Should you experience any of the complications that normally call for C-section – for example, breach birth or twins – you should not object to a cesarean section for the safety of your child. But by no means should it be performed automatically just because you are spinal cord injured.

IMPORTANT NOTE: You must be prepared to take control and insist on proper care if you get hypertensive or autonomic dysreflexia, especially if the staff is unfamiliar with spinal cord injury. Insist that treatment begin immediately. Also, carry a dysreflexia ID card with you to the obstetrician.

If I have no sensation in my lower extremities, will I know I'm in labor?

If this is your first pregnancy and your level of injury is at T12 or above, there is a possibility you may not know you are in labor. Consequently, closely monitor your bodily responses and schedule weekly visits to your obstetrician by the time you reach the seventh month of pregnancy. Up until this time, you should be seen monthly by the obstetrician. In some cases, doctors may recommend that you be hospitalized after your 32nd week, since premature labor is common. Often, however, the start of labor presents warning signs that you can note yourself: menstrual-type cramping, spotting, increased spasticity, and of course, the “water breaking” or rupture of the amniotic sac. In any event, you must be attentive to your own bodily functions and to any “messages” your body may be trying to send.

Will I be able to breastfeed?

There is no reason why you should not breastfeed your child if you so choose. If you have some upper extremity impairment or loss of strength, ask your nurse or possibly an occupational or physical therapist to help with positioning the infant. Sometimes a properly placed pillow is all you need to counteract a lack of strength or mobility. Be sure to check whether any medication you may be taking, either routinely or temporarily, is safe for your baby since many medications may leave traces in your breast milk.

Whether or not you breastfeed your baby is your individual choice. Do not feel obligated to breastfeed if you think you can better care for your child by formula feeding. Likewise, do not be dissuaded from breastfeeding if you prefer this method of feeding.

Will my physical disability affect the care of my child?

Your disability affects all aspects of your life, but just as you've adapted to other activities, you will adapt to caring for your child. Don't be concerned that your child will think of you as different. Your baby will naturally accept your way of looking after him or her; he or she will not have known any other way. As babies are adaptable themselves, you will soon find your baby scrambling into your wheelchair with little assistance or balancing on your lap for a ride. Even if you feel you have certain limitations, there are ways to deal with them.

Will I need any special equipment to care for my baby at home?

You will not necessarily need to purchase special devices for childcare, but there are a few such items on the market. Keeping in mind your specific limitations, look for items to help with the care and handling of the child from infancy through early childhood. Instead of ordering a custom-built crib, look for a commercial crib with an opening that best suits your balance and strength. There are also portable cribs that allow you to raise the height of the mattress so you don't have to bend as far to pick up the baby; however, as the child begins to stand you will need to lower the mattress height so your child cannot climb or fall out. With your child standing up at the crib's railing, this too will make it easier to pick up your child as he or she grows. With portable cribs, you can also move the baby about since these cribs are lightweight and roll easily on casters.

It is very important to set up a functional working area in your home, so you can safely change the child's diaper and bathe the baby. Many people in wheelchairs have found that a table-like desk with closed sides is just the right height to sit at and care for the child. A crib-top changer, available in most department stores, will have a pad, compartments for pins, ointment, etc., and a safety belt to prevent the baby from rolling off onto the floor. These crib-top changers may be placed on top of your work area.

The key to successful childcare is to plan ahead and try to set up an area that helps you perform your tasks as efficiently and safely as possible.

How will I carry my baby and still push my wheelchair?

Most mothers are able to develop techniques that are comfortable for them. You can use a baby sling to safely carry your baby. When the baby is old enough to sit up, you can purchase an infant harness and strap the child on your lap to safely transport. In addition to securing the baby in your lap when you are moving in a wheelchair, it also keeps an active child from running off when you are away from home with him or her. Most children get used to wearing the harness and do not object to the restraint. A harness will save you the frustration or fear of seeing your child dash off into the street. Be sure, however, to keep the line short enough so that neither you nor child will become entangled. Of course, the commercially sold baby carriers that allow the baby to rest on your chest and to breastfeed are invaluable while your child is still small.

Keep in mind that your physical therapist, occupational therapist and rehab nurse are available for adaptive training for feeding, dressing, grooming, bathing, transfers of a child for transporting and changing of diapers, etc. Let your physician know you are considering having a child, and discuss any potential medical issues with him or her. Once you become pregnant, ask for a referral to occupational and physical therapy and to a seating clinic for sitting balance changes requiring adjustments to your wheelchair due to changes in the size of your body.

WELLNESS AND RESILIENCE

Making Choices to Support Health and Well-Being

While in rehabilitation, many find themselves seeking means to enhance their well-being. Some have found themselves using ways that are familiar, while others may identify new ways to assist them in journeying through this time.

For many, this involves the concept of wellness.

- Wellness encompasses how people feel about various aspects of their lives.
- Interrelated aspects of human life comprise wellness. Our focus will include physical, emotional, social and spiritual. We will then look at resilience and how we may enhance it in our lives.

Lifestyle Enhancement

Improving your level of wellness may involve some significant lifestyle changes, such as your eating habits, physical fitness, stress management and other practices that we will cover in this chapter. The important thing is to get started by making changes in daily routines. Choose activities that you enjoy or assist someone else in doing daily tasks. Keep your goals measurable and attainable.

COMPONENTS OF WELLNESS

Physical Wellness

The benefits of staying physically active include feeling better physically and psychologically. Activity can decrease our stress level.

How Do I get Started?

First identify your areas of interest. You may find yourself choosing activities that you enjoy or participated in before your injury. Most activities can be modified to your ability level.

Thankfully, there are several resources in the community to assist you in overcoming challenges to pursuing a fitness/wellness program. You may have questions related to finance, transportation, access or building your own endurance. Carolinas Rehabilitation is available as a resource as well as many local agencies. Look for peer support groups or other people in the community. Ask family members for encouragement in helping you achieve your wellness goals.

Finally, get active! Assisting in any type of mobility at home all the way to participating in competitive athletics can improve your level of wellness. Start with a realistic goal and keep moving forward.

Additional Considerations

Smoking Cessation

If you were a smoker prior to your injury and hospitalization, you may or may not have thought about quitting. Since you have not been able to smoke since your hospitalization, this can be an excellent time for you to quit for good. There are many reasons not to smoke, with one being an increased risk for heart and lung diseases, including cancer. Cost can also be a motivating factor to change this habit. If you are a long time smoker it can be a difficult habit to break without help, but fortunately help is available. Some smoking cessation resources you might want to check out include:

- Contact the American Lung Association for information on programs and services: 800-586-4872.
- In Charlotte, there is a self-help group called Nicotine Anonymous, a 12-step program. Call 1-877-879-6422 or check out www.nicotine-anonymous.org for meeting information.
- Speak with your doctor about medications, nicotine patches or other options to help you stay tobacco free.

Substance Abuse

There are many reasons to avoid alcohol and recreational drugs after a SCI. Some of you drank occasionally, socially or may have avoided alcohol completely.

There are increased risks for those with a SCI. Please discuss this with your physician. If you suspect you have a problem, seek counsel and support. The official website for Alcoholics Anonymous is www.aa.org for information on local meetings.

EMOTIONAL WELLNESS

Emotional wellness refers to awareness, sensitivity and acceptance of feelings and the ability to successfully express and manage one's feelings.

Emotional wellness enables people to cope with stress, maintain satisfying relationships with family and friends and assume responsibility for their actions.

Self Awareness

This includes being able to monitor your feelings, mood and self-image, in order to make a change in your environment that will have a positive impact. Some areas to consider are the following:

1. Stress Management

It has been stated that we "have the optimal amount of stress if the challenges [we] face are evenly matched by [our] ability to respond while still maintaining well-being" (Sood, 2010, p. 14). Thankfully, we can strengthen our ability to respond. This is something we will continue to cover.

There are a variety of ways that people find to manage stress or connect with a sense of growth:

- Aerobic exercise
- Meditation or prayer
- Deep breathing
- Massage
- Guided imagery
- Acupuncture or acupressure
- Social interaction
- Hobbies or volunteer work
- Getting enough sleep, eating a proper diet, avoiding excess caffeine and other stimulants

2. Motivation

This can be internal or external. You may be motivated by goals that other people set for you, or you may be able to motivate and challenge yourself to reach your own goals. Either way, it is important to find which one works for you in order to achieve your rehab, fitness and life goals. Being motivated to achieve a healthy balance between productive activities, rest and leisure pursuits can lead to a favorable adjustment for all of us.

Resilience

Resilience is a concept that is becoming more frequently studied. It is about making our wellness hardy. Some definitions of resilience are below:

“Resilience implies that [people] are able to negotiate significant challenges to development yet consistently ‘snap back’ in order to complete the important developmental tasks that confront them as they grow. Unlike the term survivor, resilient emphasizes that people do more than merely get through difficult emotional experiences, hanging onto inner equilibrium by a thread.” (Higgins, 1994, p. 1)

For others, resilience has been through of a component of flourishing:

“[The University of Cambridge’s Well-Being Institute] measured flourishing, which they defined as having positive emotion, plus being high on any three of the following: self-esteem, optimism, resilience, vitality, self-determination and positive relationships.” (Seligman, 2011. p. 228).

Common factors of people who have resilience are the following:

1. They are resourceful and have good problem-solving skills.
2. They are more likely to seek help.
3. They hold the belief that they can do something that will help them to manage their feelings and to cope.
4. They have social support available to them.
5. They are connected with others such as family and friends.

(Brown, 2010, p. 64)

When we read these descriptions of resilience, we sometimes may think that if we do not have some of these elements in our lives, we cannot be resilient, but this is not so. We can always enhance our resilience. You may have heard of people who have become truly outstanding only have a significant challenge or even tragedy has struck their lives. You could be one of them.

Another definition is that “resilience refers to your ability to not only withstand adversity, but bounce back ever so higher, sometimes even because of your adversity. Resilience emerges when you are grateful for your blessings, when you accept the present moment and its contents, when your compassion effortlessly flows toward self and others, when you cultivate greater forgiveness, and when you are anchored in a higher meaning or purpose of your life” (Sood, 2010, p.5).

Principles of Resilience

Ways we will focus on engaging that part of ourselves that promotes peace and well-being.

Principles of resilience include (Sood, 2010):

- Compassion
- Meaning
- Meditation
- Gratitude

Compassion

Compassion is another principle that can assist us in our lives, particularly by being compassionate towards ourselves and others; both help us to feel better.

Self-Compassion

Kristin Neff, PhD (2010, p. 42) noted that, “self-kindness involves more than merely stopping self-judgment. It involves actively comforting ourselves, responding just as we would to a dear friend in need... With self-kindness, we soothe and calm our troubled minds. We make a peace offering of warmth, gentleness and sympathy from ourselves, so that true healing can occur.”

- We are compassionate to others because it enhances their healing and is the right thing to do.
- Compassion to ourselves promotes our well-being and the well-being of others. Chris Germer, PhD noted how we can give ourselves compassion (May 2013).

Steps involved:

- We note that we have a sense of suffering in the present moment.
- We create space for experience.
- We hold ourselves with kindness. We give compassion to ourselves not to make suffering go away, but because we are suffering.
- We allow wisdom to emerge.

Meaning

Another source of strength is from our sense of meaning. As categorized by Amit Sood (2010, p. 252), meaning can be accessed in the following ways:

1. By belonging
2. By doing (work or leisure activities)
3. By understanding oneself and the world (this may be spiritual)

Benefits of Finding Meaning

Connecting with our sense of meaning strengthens us when we face life challenges and simply enhances our day to day sense of well-being (Sood, 2010).

Meditation

In his book on relaxation and reducing stress, Davis (2000), notes that medication is another practice that may enhance your well-being. Common ways of meditating include:

- Counting breath
- Mantra
- Mindfulness
- Centering prayer

Online resources for meditation include:

- Center for Mindful Self Compassion Meditations and PDF files: www.centerformsc.org/meditations
- Guided Imagery: www.healthjourneys.com

Gratitude

Exercises to increase gratitude in our lives (Sood, 2010, p. 188-189):

- Saying thank you in the morning. Spend some time first thing in the morning noting gratitude. If you are able, start with noting five things.
- While going about your day, say thank you to at least one person- this could be verbally, in an email, card, gift or even just in your mind.
- Before you go to sleep at the end of the day, note something (or somethings) for which you feel grateful.

MEDICAL MANAGEMENT

Medical management is crucial for those with spinal cord injury in order to remain healthy and to address any complications that may arise. Keep all scheduled appointments and follow directions for medications. Keep free of pressure sores by doing pressure reliefs, and strictly follow established bowel and bladder programs. Consult with your doctor before starting a physical fitness program.

Two specific health issues you should pay special attention to are cardiovascular disease and diabetes.

Cardiovascular Disease includes heart attacks, high blood pressure (hypertension), stroke and clogged arteries (peripheral vascular disease). Heart disease causes or contributes to 22 percent of deaths among those with spinal cord injury. Cardiovascular problems, in general, are 200 percent higher than expected in age and gender-matched groups of people. Cardiovascular disease is the most frequent cause of death in people who have had a spinal cord injury over 30 years.

Type II Diabetes occurs when your body does not produce enough insulin or when your cells ignore the insulin that is present. Insulin moves sugar (glucose) from your blood into your cells where it is used for energy. Glucose left in your blood can lead to the following complications: blindness, kidney failure, heart disease, peripheral artery disease, nerve damage, high blood pressure and stroke.

The risk of developing Type II diabetes increases 20 percent after a spinal cord injury and has three times the incidence as compared to the non-injured population (americandiabetesassociation.org).

You can lessen your risk of developing cardiovascular problems and diabetes by controlling your cholesterol, blood sugar and overall weight. Stay as physically active as possible. Manage your stress levels, and avoid smoking.

How Do I Get Started?

First, you must overcome barriers that might prevent you from pursuing a fitness/wellness program. These barriers may be financial, related to transportation, a decrease in endurance or may be the actual physical layout of a building for those in wheelchairs. Fortunately, there are several resources in the community to assist you. Carolinas Rehabilitation is available as a resource, as well as many local agencies. Look for peer support groups or other people in the community. Ask family members for encouragement in helping you achieve your wellness goals.

Choose activities that you enjoy or participated in before your injury. Most activities can be modified to your ability level.

Finally, get active! From participating in any type of mobility at home to participating in competitive athletics, you can improve your level of wellness. Start with a realistic goal, and keep moving forward.

Healthy Lifestyle

A healthy lifestyle is a choice, and it is also your responsibility. When we take responsibility for our wellness, we are more likely to take action to make things better and accept ourselves and others as they are.

DEALING WITH SPINAL CORD INJURY: CONSIDERATIONS FOR YOU

Particularly through these exercises, or perhaps through other practices you already do or find, you can strengthen your sense of resilience. You may have heard of people who have become truly outstanding only after a significant or life-changing challenge touched their lives. You could be one of them.

Celebrate Your Victories

Recovering from a spinal cord injury is hard work. Chances are good that the new thing that you can do now took you a lot of effort to get right. Congratulate yourself for working hard and being determined enough to succeed. In a while, you will begin to see more and more progress – be open to what progress might look like for you whether it is mentally, physically, spiritually or emotionally. Every time that you succeed at something new, celebrate a little.

Reaching Out for Support if You Need it:

- Talk to a psychologist, counselor, spiritual leader or wise friend to help you cope with your feelings. Local behavioral health agencies provide services for both mental health and substance abuse needs. Mecklenburg County residents call 704-444-2400. Cleveland, Gaston and Lincoln County residents call 704-884-2501. Cabarrus, Davidson, Rowan, Union and Stanly County residents call 800-939-5911. Complete resources can be found online at dhhs.state.nc. There are therapists familiar with SCI that can help. Ask your doctor for a referral.
- Engage in exercises to assist you in being resilient. Seek counsel or guidance from clergy.
- Talk to your doctor about how you are doing
- Seek fellowship with other people going through the same thing. There is a social and support group that meets monthly Charlotte for those with SCI. Your social worker can give you more information.
- Visit online resources like paralysis.org.
- Consider adaptive sports (ASAP program), as these programs can be good for the body and soul, and exercise can lift your spirits in a healthy way.
- If you met one of the peer mentors while you were here, and found the support and knowledge helpful, the relationship can continue after you go home. Exchange contact information with him/her before you leave.

If you are having thoughts of self-harm or suicide, you need help immediately to help you through this crisis. PLEASE confide in a trusted family member or medical professional and get help. Call 911 for the police, or contact the Behavioral Health Center in Charlotte at 704-444-2400.

A Final Word

At Carolinas Rehabilitation, we are committed to providing excellent and compassionate care to our patients and their loved ones. Many of the new skills that you need will take some practice and you may see that it is best to get started as early as possible. Our healthcare team will support you in your learning process. You are a vital part of our care team at Carolinas Rehabilitation.

REFERENCES

1. Bartel M. *What is spiritual? What is spiritual suffering?* J Pastoral Care Counsel 2004; 58:187-201.
2. Brown, Brené. *The Gifts of Imperfection*. Center City: Hazelden, 2010.
3. Davis M, Eshelman ER, McKay M. *The Relaxation and Stress Reduction Workbook*. New York: MJF Books, 2000.
4. Germer, C. (2013, May). *Lecture conducted at Mindful Self-Compassion Training*, Center for Mindful Self-Compassion, Petaluma, CA.
5. Germer, C. and Neff, K. *Meditations*. Center for Mindful Self-Compassion. Retrieved October 29, 2013 from <http://www.centerformsc.org/meditations>.
6. Henson, Darren. *A Beginner's Mind*. 1998. Mew Hing Productions. January 4, 2013. <http://www.ironpalm.com/beginner.html>
7. Higgins, Gina O'Connell. *Resilient Adults, Overcoming a Cruel Past*. San Francisco: Jossey-Bass, Inc., Publishers, 1994.
8. Naparstek, Belleruth. *Health Journeys, Resources for Mind, Body, and Spirit*. Retrieved October 29, 2013 from <http://www.healthjourneys.com/default.asp>.
9. Neff, Kristin. *Self-Compassion*. New York: Harper Collins e-books, 2011.
10. Neff, Kristin and Germer, Chris (2013). *A Pilot Study and Randomized Controlled Trial of the Mindful Self-Compassion Program*. Journal of Clinical Psychology. Volume 69, Issue 1, 28-44.
11. Seligman, Martin. *Flourish*. New York: Simon and Schuster, 2011.
12. Sood, Amit. *Train Your Brain....Engage Your Heart....Transform Your Life: A Course in Attention & Interpretation Therapy (AIT)*. Rochester, MN: Morning Dew Publications, 2010.

One

SECTION V

FINANCIAL AND COMMUNITY RESOURCES

Introduction

How can I get help with things like money and housing?

There are some limited resources available for help. Your social worker can assist you in locating which resources may be able to address your needs. Programs vary regarding eligibility requirements.

If have to call an agency or insurance company, how can I help them help me?

Agencies will typically need to know the information that will help them determine if you qualify for the services they offer. This information may include the nature of injury, physical limitations associated with illness/injury and financial information. Insurance companies will need to know the policy number and group number. This information can be found on your insurance card. Prior to calling an agency or insurance company, it may be helpful to write down a list of questions. Also, when getting information from an agency or insurance company, write down the name of the person giving the information. This may be helpful in the future if you need to call back to get additional information. If you feel the person you're talking to is not sure of the information, you can ask to talk to a supervisor.

What if I need help with things like insurance or dealing with a government agency?

Let your social worker know that you need help. The social worker may be able to assist you in determining resources for information about your insurance coverage and issues involving government agencies.

Social Security Disability

How do I get disability benefits?

You or your family should call, go to the Social Security website online, or visit any Social Security office to initiate an application for disability benefits. Your social worker can give you a phone number, or you can look it up online or in the phone book. Social Security will ask you to fill out forms listing the doctors you have seen, hospitals you have been in and jobs you have held, in addition to other information.

Would it be faster for my doctor to write to Social Security and tell them I'm disabled?

No. The government decides if you are disabled enough to get disability benefits by looking at copies of your medical records and other information. The application process can take three to five months. There is a five-month waiting period and your first Social Security disability benefits will be paid for the sixth full month after the date your disability, according to the Social Security Administration (Disability Benefits. SSA publication No. 05-10029icn 456000. 2012, June).

What if I'm turned down for benefits from Social Security?

See the page in this notebook on appeals.

How long will I receive benefits?

You will receive benefits as long as you are unable to work, until you reach full retirement age.

What if I'm old enough to retire?

You should talk to Social Security about retirement benefits. Also, talk to the people you worked for, to see if there are any benefits through them.

Supplemental Security Income (SSI)

Can I get help from Social Security if I can't get a Social Security or disability benefits or if these benefits are very small?

You may be able to get SSI benefits if you are elderly, blind or disabled and have very little income or resources.

How much can I have and still get SSI?

This can change from year to year. Social Security can tell you the exact amount.

Can I get SSI even if I have never paid Social Security taxes?

Yes.

How long does it take to get SSI?

Contact Social Security to find out when you may be able to begin receiving payments and what the payment amount will be.

Can I get SSI and disability or Social Security?

You may be able to. Contact Social Security for more information.

Medicare

How do I get Medicare?

Medicare eligibility starts after you get 24 months of disability benefits. If you turn 65 before you get 24 months of disability benefits, Medicare will start when you turn 65, if you are eligible to get Social Security benefits. Contact Social Security with any questions about this, or to find out if you could be eligible for Medicare even if you do not meet these requirements.

How can Medicare help me?

Medicare is health insurance. It will cover some of your medical bills but not all of your medical bills.

Do I need other insurance if I get Medicare?

It is a good idea to consider the benefits of having a supplemental insurance policy that assist with the cost that Medicare does not cover. Medicare benefits have limitations and do not cover everything. To get an explanation of what Medicare covers and the amounts covered, visit the Medicare website, contact the Medicare office to request a booklet or speak with a representative by calling 800-633-4227.

County Department of Social Services (DSS)

What kind of help can I get at DSS?

You may be able to get Medicaid, food stamps, or other assistance. Your (or a family member or friend) can contact the DSS in your county to request information about assistance programs available through DSS. You can find the phone number in the phone book, look it up on the local DSS website or ask your social worker. Usually, DSS will want to set up a time for someone to come to their office to complete applications for assistance. If you do not have anyone available to assist you, please let your social worker know.

How much money can I have and still get DSS to help?

The amount is not the same in every program and is not the same in every state. DSS can give you the exact amount.

What if I am turned down for benefits from DSS?

See the appeals section in this notebook.

What is Medicaid?

Medicaid is a program set up to cover some of the medical costs of people who have low income and savings and are also elderly or disabled or have children.

What will Medicaid pay for?

What Medicaid pays for can change from year to year and is not the same in every state. Medicaid has some limited services for in-home care that is not typically covered by traditional insurance policies or Medicare. If you think you will need help in paying for your medical expenses, medications, or will need assistance with in-home care, please let your social worker know. The social worker can provide information and some assistance with getting a Medicaid application started.

Can I have Medicaid if I have Medicare or insurance?

Yes. Medicaid may help pay for your Medicare premiums and some services Medicare or insurance will not cover.

What other help can I get from DSS?

Other programs such as food/nutrition assistance services, general or crisis assistance, in-home aide services or transportation may be available. Programs vary by country and many programs have long waiting lists. Eligibility requirements vary by program and state. Contact your local DSS to inquire about assistance that may be available to you and how to apply. DSS may also know of other kinds of help available from different local resources.

Going Back to Work

Can I get help to get back to work?

Yes. Vocational rehabilitation (VR) is a state program that can help you get back to work. They offer a variety of services that can include evaluations, training, modifications to home, work locations or vehicles and may help pay for things to help you get back to work such as medical care, schooling, or modifications for your home. If you are eligible, they will work with you to develop a plan specific to you. Let your physician or social worker know if you want to see a VR counselor.

Is VR the same in every state?

Most of the services are the same, but there may be some differences in different states.

What if I'm not ready to think about working, but I need the kind of help VR gives, like making my home easier to navigate?

Some counties have an Independent Living Services program that may be able to help. Independent Living Services in North Carolina may be able to provide limited funding for some home modifications or adaptive equipment needs to promote independent living. If you have a VR counselor, ask them if your county has an independent living program. You can also look up contact information on the internet to find a local office or contact your social worker if you have additional questions or need assistance.

Counseling

What if my family or I get depressed or find it hard to cope after I get home?

If you or your family are having difficulty coping, counseling services may be helpful. Counseling services are available to you while you are a patient at Carolinas Rehabilitation. Once you go home, other services may be available. Available mental health services vary by state, such as through a Local Management Entity in North Carolina or Community Mental Health Centers in South Carolina. If you have insurance, you may have benefits for counseling services. You can contact your insurance company to determine what services are covered and request assistance with locating a counselor. If you have a home health company providing services in the home, they may be able to send a social worker to your home who can counsel you or your family or connect you to services. If you are having trouble getting counseling services arranged, let your primary care physician know. They may be able to help you. If you do not have a primary care physician, contact your local Department of Social Services, local mental health center, or local management entity.

Isn't counseling very expensive?

Counseling services may be covered by your insurance. If you do not have insurance, you may be able to receive reduced fees or sliding scale services, based on your income.

Housing

How do I find a place to live?

There is very limited assistance available for this. Check online for information about housing availability in your area. If you live in the Charlotte area, you could contact Disability Rights and Resources to see if they can provide any guidance or help with this. You can contact them by calling 704-537-0550, 800-755-5749 or visit them on their website Disability-Rights.org. Other cities may have similar services. You can call the Charlotte office to see if they can refer you to a similar resource in your community. Or, you can check for a listing in your local phone book, the internet or contact your local Department of Social Services office.

What if I can't afford to pay much rent?

Many cities and counties have a housing authority which offers assistance with rental housing, and/or the waiting lists are closed in many places. They also usually have some housing that will fit a wheelchair. There are often long waiting lists for this type of housing. You can find the number for the housing authority in the phone book or online or you can ask your social worker to assist you to obtain the contact information.

Department of Veterans Affairs (VA)

How does a veteran or veteran's family get help from the VA?

The VA has many programs for veterans and their families. They may be able to help provide some of your care or provide monetary assistance for your care. The best way to apply is to call the Veterans Service Office in your county.

Transportation

How do I get around after I leave the hospital if I can't drive?

In Charlotte, the Charlotte Area Transit System has wheelchair-accessible buses. Call the Charlotte Area Transit for bus schedules and routes. The cost to ride is regular bus fare. You may also be eligible for the Special Transportation Service. This is an accessible transportation service for people with disabilities. You must apply for service ahead of time and trips must be scheduled in advance. Other cities/counties may have similar type services. You would need to check with your local city's Department of Public Transportation. If you think you may need assistance with transportation, let your social worker know.

What if there is no transportation service where I live?

It may be very hard to get help. Some groups like churches and special interest clubs can provide some help. Most communities have some type of taxi service or private pay wheelchair transport companies available. However, these services have costs attached to them that can become very expensive.

Can DSS help with transportation?

You may be able to get assistance with transportation for medical appointments. Medicaid generally will cover transportation for medical appointments. Contact your local DSS to inquire about programs/eligibility.

How can I get a tag to park in a handicap parking zone?

If you are from North or South Carolina, you can get an application from your social worker or your local Department of Motor Vehicles. If you are from another state, call or go to the local Department of Motor Vehicles to get an application.

Home Care

What if I don't have enough family to do all my care?

Please let your social worker know as soon as you can. If you have North Carolina Medicaid, you may be able to receive an aide in the home through Personal Care Services or Community Alternatives Program (CAP). There are often long waiting lists for the CAP program.

Won't Medicare pay for my care at home?

Medicare will only pay for in-and-out care. It will pay for a nurse or therapist to go to your home a few hours a week if you need things done that only a nurse or therapist can do. While you need a nurse or therapist, Medicare will also pay for an aide to come in a few hours a week to do things like give you a bath. Medicare will not pay for someone to stay with you all day.

Will insurance pay for more home care?

Every insurance policy is different. Some pay for home care just like Medicare. Some pay for more, some for less, and some do not pay any.

Personal Attendant Management

You may choose to seek physical assistance from a paid caregiver or attendant. There are many things to be considered before hiring an attendant. Some of these are:

- Determine the specific tasks you need help to complete
- Determine the duties, expectations, hours and salary for the position Consider how best to cover the various times you will need someone, e.g. 24/7 versus four hours a day
- How to recruit someone, where to find a personal attendant
- How to conduct an interview
- How to check for references and criminal background
- How to supervise, teach, and correct or discipline an attendant
- Issues about salary, taxes, labor laws and insurance
- Have a back-up plan to cover employee illness, vacation or termination

SECTION V

Studying and analyzing as many aspects of attendant care situations as possible, and then preparing for them has proven to be the best way to be successful at finding and keeping a good personal care attendant.

There is an excellent resource from Paralyzed Veterans of America (PVA) that gives extensive directions and information on the topic of attendant care management. You can download a free electronic copy or obtain a printed copy for free (plus shipping and handling) from their website.

*“Managing Personal Assistants: A Consumer Guide,” from PVA for \$11.95.
1-888-424-8200, publication #2900-143*

In the Charlotte area, you may also be able to access additional information by calling Disability Rights and Resources 704-537-0550, 1-800-755-5749 or visit them on their website Disability-Rights.org

Insurance

How can I find out what my insurance covers?

If you have insurance through your job, the human resources office where you work should be able to answer questions about your insurance. If you’re carrying the insurance on your own, talk to the insurance company. You can also check your benefit policy booklet and/or call the number on the back of your insurance card.

I have insurance through my job. Do I have to do anything so it will continue while I’m out of work?

Ask the human resources office where you worked about this. If they tell you that because you are not working there either you will lose your insurance or your premiums will go so high you cannot afford them, let your social worker know right away. There are laws that often mean the people you worked for have to keep up your insurance, but lets them charge you more than you paid while you were working.

Can I get sick pay from my job?

Ask the human resources office where you worked about this. Many companies offer sick pay for a short time. Some may even have disability pay.

If I can get disability pay from my job, do I still need to apply at Social Security?

Yes. Social Security will pay as long as you are disabled. A check from your job is usually for a shorter time and will often be reduced by the amount Social Security will pay you.

Lawyers

I have a lawyer and expect to get a lot of money when we sue the person who caused my injury. Do I need to think about things like insurance and disability?

Ask your lawyer about this and follow his or her advice. Remember that lawsuits sometimes take a long time and you may need an income and a way to pay for things like medicine and a wheelchair before the lawsuit is settled.

What if I want to get help from a lawyer but I can't afford one?

Most communities have a service called legal aid. Legal aid provides service free or at a reduced based on various factors. You can look in your local phone book or on the internet for a phone number. If you need assistance getting in touch with legal aid, let your social worker know.

Workers' Compensation (Comp)

What if I got hurt on the job?

You may be able to get workers' compensation to cover your medical bills. Workers' compensation will often even pay for things like changes to your home to fit a wheelchair. Almost no other insurance will pay for these non-medical costs.

What if I get hurt on the job and have not heard from workers' compensation?

Let your social worker know. There are few jobs that are not covered by worker's comp. You can contact your employer's human resource office to check to see if you are covered by worker's compensation.

Appeals

What if I got turned down for benefits?

Almost all decisions can be appealed. If you try to get help from a government program, and they tell you that you cannot get it, read the letter saying you cannot get the help. It will usually tell you what you need to do to appeal. If you do not understand the directions, call the agency and ask how to appeal. You need to follow the directions exactly. If you don't, that may be a reason for the appeal to be denied.

Can I appeal a decision by my insurance company not to cover something?

You can always ask to talk to the supervisor of the person who decided not to cover it. If they are not covering something that the policy says should be covered, the state insurance commissioner's office may be able to help.

RESOURCES

There are a number of resources and publications catering to those with disability. For resources and information, visit the American Association of People with Disabilities at AAPD.com/publications

Charlotte Area Groups for Those with Spinal Cord Injuries/Diseases

Disability Rights and Resources

Disability-rights.org

5801 Executive Center Drive, Suite 101

Charlotte, NC 28212

704-537-0550 or 800-755-5749

Provides advocacy, information, and referral, including peer mentoring and information about community integration and independent living skills.

State Groups/Resources for Those with Spinal Cord Injuries/Diseases

North Carolina Spinal Cord Injury Association

NCSCIA.org

7980 Chapel Hill Road, Suite 101

Cary, NC 27513

Call 919-234-4171 or contact Board Chairperson Debbie Myers at dmyers8@triad.rr.com

They provide resources, services, peer support, information, and advocacy. They also list information about support groups throughout North Carolina.

Head and Spinal Cord Injury Division in South Carolina (HASCI)

Referral number is 866-867-3864. Services may include service coordination, information and referral, waiver programs, modifications and other services. Contacting HASCI as soon as possible is encouraged because there is typically a waiting list.

North Carolina Assistive Technology Program

NCATP.org

The North Carolina Assistive Technology Program (NCATP) leads North Carolina's efforts to carry out the federal Assistive Technology Act of 2004. NCATP promotes independence for people with disabilities through access to technology.

Publications and Resources

For a list of publications and resources catering to those with disability, visit Disability.gov

Blogs

Do It Myself Blog

Doitmyselfblog.com

Glenda Watson Hyatt shares her experiences living with cerebral palsy to motivate and inspire others to think about how they perceive their own situation and their own world around them.

Ouch! (BBC Disability blog)

BBC.com/news/blogs/ouch

Program by the British Broadcasting Corporation that explores disability.

Magazines

Ability Magazine

Abilitymagazine.com

The first newsstand magazine focused on issues of health and disability.

inMotion Magazine

Amputee-coalition.org/limb-loss-resource-center/publications/inmotion

inMotion magazine is published bimonthly for amputees, caregivers and healthcare professionals, providing timely and comprehensive information. To subscribe, call toll-free at 888-267-5669.

New Mobility

NewMobility.com

The magazine for active wheelchair users. To subscribe, call 800-404-2898 (ext. 7203).

National Groups

Some of the national groups dealing with spinal cord injuries are:

Christopher & Dana Reeve Foundation

Christopherreeve.org
636 Morris Turnpike
Suite 3A
Short Hills, NJ 07078
800-225-0292

The Christopher & Dana Reeve Foundation is dedicated to curing spinal cord injury by funding innovative research and improving the quality of life for people living with paralysis through grants, information and advocacy.

National Spinal Cord Injury Association

8300 Colesville Rd.
Suite 551
Silver Springs, MD 20910
800-962-9629

They publish two excellent sources of information: National Resource Directory and Spinal Network (a book, not the magazine listed in the magazine section). They also provide a newsletter, peer support, and information on recreation and fitness, and are involved in research.

Paralyzed Veterans of America

801 18th St.
N.W., Washington, D.C.
202-872-1300

Membership is open only to veterans, but it has many programs open to anyone. It publishes a magazine and is involved in sports, advocacy, research and other activities. It has chapters around the country.

SECTION V

National Resources

Alzheimer's Association

225 N. Michigan Ave., Fl. 17
Chicago, IL 60601
312-335-8700

American Paraplegia Society

75-20 Astoria Boulevard
Jackson Heights, NY 11370
718-803-3782

American Parkinson Disease Association

60 Bay Street
Staten Island, NY 10301
800-223-2732

American Heart Association, National Center

7320 Greenville Avenue
Dallas, TX 75231
214-373-6300

Arthritis Foundation

1314 Spring Street NW
Atlanta, GA 30309
404-872-7100

Brain Injury Association

1776 Massachusetts Ave NW
Suite 100
Washington, DC 20036
800-444-6443

Epilepsy Foundation of America

4351 Garden City Drive
Landover, MD 20785
301-459-3700

High Blood Pressure Information Center

102/80 National Institutes of Health
Bethesda, MD 20892

Multiple Sclerosis Society

6350 N. Andrews Ave.
Ft. Lauderdale, FL 33309
800-441-7055

National Institute on Aging Information Center

2650 Pittman Drive
Silver Spring, MD 20910
301-587-2528

National Headache Foundation

5252 N. Western Avenue
Chicago, IL 60625
800-843-2256

National Stroke Association

300 E. Hampden Avenue
Suite 240
Englewood, CO 80110
800-787-6537 or 800-STROKES

SECTION V

National Chronic Pain Outreach Association

7979 Old Georgetown rd.
Suite 100
Bethesda, MD 20814
301-652-4948

National Foundation for Depressive Illnesses

P.O. box 2257
New York, NY 10116
800-248-4344

National Easter Seal Society Inc.

230 W. Monroe St.
Suite 1800
Chicago, IL 60606

National Spinal Cord Injury Association

545 Concord Avenue
Cambridge, MA 02138
800-962-9629

Stroke Connection of the American Heart Association

7272 Greenville Avenue
Dallas, TX 75231
800-553-6321

The AVM Support Group

Ateriovenous

107 Bella Vista Way
San Francisco, CA 94127
415-334-8012

Malformation

U.S. Department of Justice Civil Rights
Division/Coodination and Review Section

P.O. Box 66118
Washington, DC 20035
202-514-0301

EMERGENCY PREPAREDNESS

Organizations such as the American Red Cross *Redcross.org* and Federal Emergency Management Agency (FEMA) *FEMA.gov* stress the importance of emergency preparedness in case of natural or manmade disaster. This personal assessment tool can be used to help you prepare for a local or regional emergency, such as a flood, hurricane, earthquake or fire. Planning ahead is the best thing you can do to have your needs met during a disaster situation.

This guide will help you take the steps necessary to prepare for an emergency before it is too late. The exact steps you should take will vary depending on your specific medical needs and the community in which you live.

EMERGENCY PREPAREDNESS GUIDE

You should decide what you will be able to do for yourself and what assistance you may need before, during and after an emergency.

Personal Care: Do you need assistance with personal care, such as bathing and grooming? Do you use adaptive equipment to help you get dressed?

Current Situation/Procedures:

Assistance I may need due to a disaster:

<hr/>	<hr/>
<hr/>	<hr/>
<hr/>	<hr/>

Water Service: What will you do if water service is cut off for several days, or if you are unable to heat water?

Current Situation/Procedures:

Assistance I may need due to a disaster:

<hr/>	<hr/>
<hr/>	<hr/>
<hr/>	<hr/>

Adaptive Feeding Devices: Do you use special utensils that help you prepare or eat food independently?

Current Situation/Procedures:

Assistance I may need due to a disaster:

<hr/>	<hr/>
<hr/>	<hr/>
<hr/>	<hr/>

Electricity-Dependent Equipment: How will you continue to use equipment that runs on electricity, such as ventilators, dialysis, electrical lifts, etc.?

Current Situation/Procedures:

Assistance I may need due to a disaster:

<hr/>	<hr/>
<hr/>	<hr/>
<hr/>	<hr/>

SECTION V

Disaster Debris: How will you cope with the debris in your home following the disaster?

Current Situation/Procedures:

Assistance I may need due to a disaster:

Transportation: Do you need a specially-equipped vehicle or accessible transportation?

Current Situation/Procedures:

Assistance I may need due to a disaster:

Evacuating: Do you need help to leave your home or office?

Current Situation/Procedures:

Assistance I may need due to a disaster:

Building Exits: If the elevator is not working or cannot be used, are there other exits?

Current Situation/Procedures:

Assistance I may need due to a disaster:

Getting Help: How will you call for help if you need to leave the building?

Current Situation/Procedures:

Assistance I may need due to a disaster:

SECTION V

Mobility Aids/Ramp Access: What will you do if you cannot find your mobility aids?
What will you do if your ramps are shaken loose or become separated from the building?

Current Situation/Procedures:

Assistance I may need due to a disaster:

Create a Personal Support Network

Organize a network for your home, work, school, volunteer site and any other place you spend a lot of time. Members of your network can be roommates, relatives, neighbors, friends and coworkers. They should be people you trust and who could check to see if you need assistance. They should know your abilities and needs, and be able to offer help within minutes. Have a minimum of three people for each site if possible.

- Explain (with clear directions and practice) to members how they can assist.
- Give your network members copies of your emergency information list, important medical information and show them how to assist with any equipment.
- Agree on how you and your network will contact each other during an emergency. (This could be knocking on walls, using whistles, flashlights, etc.)
- Give the members of your team any necessary keys they may need to gain access to you.
- Practice and update your plans often.

SECTION V

Resources for information on Emergency Preparedness

Ready North Carolina

Readync.org

Charlotte-Mecklenburg Emergency Management

Charmeckem.net

FEMA Ready America

FEMA.gov/Office-Disability-Integration-Coordination

American Red Cross

Redcross.org/prepare/disaster

DisabilityPreparedness

Disability.gov

National Organization on Disability

NOD.org/disability_resources/emergency_preparedness_for_persons_with_disabilities

The National Spinal Cord Injury Association

Spinalcord.org/resource-center

June Isaacson Kailes – Disability Policy Consultant

Jik.com/disaster.html

Summary Checklist for Personal Disaster Preparedness

Date Completed	Task
	<p>Make an emergency information list. Include:</p> <ul style="list-style-type: none"> • Medical and emergency contact information • Emergency out-of-area contacts • Names and numbers of everyone in your network • Name and number of your out-of-area contact
	<p>Fill out a medical information list. Include:</p> <ul style="list-style-type: none"> • Medical providers • Medications you use • Adaptive equipment and/or body system support equipment you use • Allergies and sensitivities • Communication or cognitive difficulties
	<p>Attach copies of health insurance cards and related information to your medical information.</p>
	<p>Keep at least a seven day supply of essential medications in your kits.</p>
	<p>Have copies of your medications.</p>
	<p>Talk with your doctor or pharmacist about what you should do if you do not have enough medications after a disaster.</p>
	<p>Identify safe places to go during an:</p> <ul style="list-style-type: none"> • Earthquake • Flood • Fire
	<p>Install at least one smoke alarm on each level of your home and outside sleeping areas.</p>
	<p>Notify your local power company and alert them if you require use of a mechanical ventilator. The number for Duke Power is 800-POWER-ON.</p>
	<p>Consider purchasing a home generator.</p>
	<p>Find the utility cutoff valves and switches. Become familiar with how to operate them.</p>
	<p>Identify as many exits as possible (at least two) from each room and from the building you are in.</p>
	<p>Practice using different ways out of the building, especially if you are above the first floor.</p>
	<p>Practice and be ready to give brief, clear, specific instructions and directions to rescue personnel.</p>
	<p>Become familiar with the emergency plan for your workplace.</p>
	<p>Choose an alternative place to stay.</p>
	<p>Have a care plan for your pet.</p>

Build a Disaster Supply Kit:

A supply kit should include supplies that will help you be self-sufficient for a MINIMUM of three days. Here are a few of the most recommended items to include but remember this kit is yours so be sure to personalize it.

- Water (one gallon per person per day)
- Radio and extra batteries
- Flashlights and glow sticks
- First aid supplies and medicine
- Tools and parts for wheelchair repair
- Whistle
- Food (non-perishable)
- Comfy clothes
- Backup equipment
- Sturdy gloves
- Extra catheters
- 80 percent of supplies listed in brochure you should already have around your home – it's just a matter of putting them in the same place.

PREPAREDNESS IS EVERYONE'S RESPONSIBILITY. TAKE AT LEAST ONE STEP TODAY!

Some of the information provided on Emergency Preparedness is generously shared by the University of Washington Medical Center and the Office of Seattle Emergency Management at Seattle.gov/emergency (206-733-7123).

HOME MODIFICATIONS

Home modifications are changes you make to your home to improve access and safety as you move from one point to another. Some of these changes may be very simple, while others may require more extensive considerations. You and your family should begin thinking about the process of making your home safe and accessible before you are discharged from the hospital. The rehabilitation staff, such as your therapists and social worker, can assist you by providing information on this topic. Remember, one of the best things you can do is to always carry your cell phone with you so that help can always be reached.

Doors

A typical wheelchair is 25 inches wide, including the wheels and push rims, and 48 inches deep. These measurements depend on many things, including the width of your seat and what type of leg rests you have, so determine your actual doorway requirements with your physical therapist.

- A minimum of 32 inches is needed to move between furniture or straight through a doorway although some narrower wheelchairs may be able to manage a 28 inch width.
- Consider removing the door frame, repositioning the door hinges, reversing the swing of the door or widening the doorway.
- Consider removing doors or installing pocket doors
- Door handles should be 36 inches from the ground
- Lever handles will be easier to manage than turn handles or knobs.
- Consider installing bumper guards at corners in hallways.

Flooring and Thresholds

- Be aware of thresholds greater than 1/2 inch or in uneven places between rooms where the flooring changes material.
- Tile and hardwoods will be the easiest to maneuver over than thicker carpets. Consider placing hard plastic runners over areas of thick carpet that will be frequently traveled, like hallways.

Room Layout

To make a U-turn in your wheelchair, you will need 60 inches or five feet of space. Consider rearranging furniture against walls or removing furniture to create more space for wheelchair mobility. This can be especially troublesome in bathrooms, kitchens and closets.

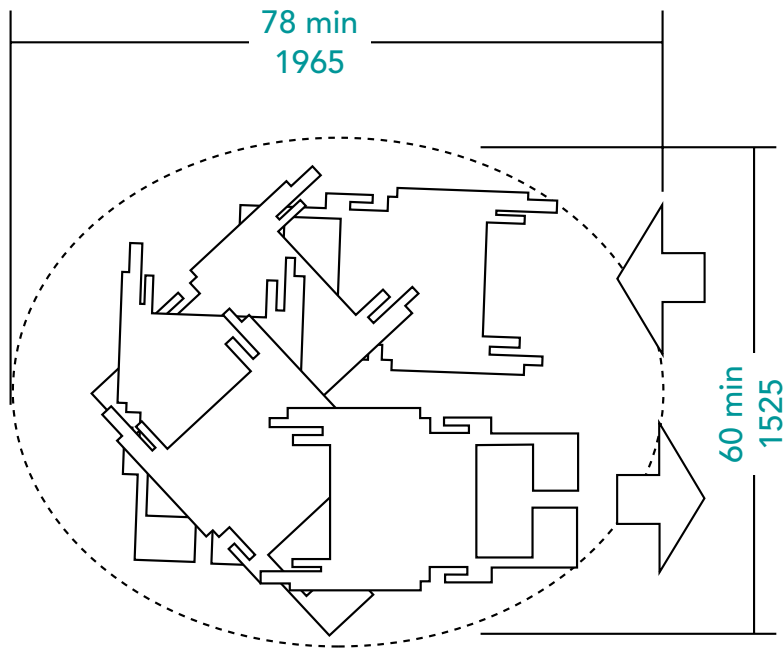

Countertops

Tables and counters should be 30 to 32 inches high and 27 to 29 inches will be required for leg clearance. This is especially important in the kitchen and the bathroom.

Bedrooms and Closets

- Your bed should be the same height as the seat of your wheelchair so you can transfer easily.
- A firm mattress will give you more support when you get dressed and transfer in and out of bed.
- You will need approximately three feet of an open floor space between pieces of furniture to move around easily.
- If you require a hospital bed, remember this will take up more space and require access to an electrical outlet. A phone and lamp should be within reach of the bed.
- There are simple, inexpensive remote control devices which can allow you to control the TV and lights from the bed. There are also more complex and expensive systems which can control many features in the environment.
- Open shelves or storage cubicles are easier than dressers to use from a wheelchair.
- Lowering closet rods to less than four feet high will help improve your access to hanging clothing.
- Outlets and switches should be at least 40 inches from the floor. Front-loading washing machines and dryers will be easier to access.

Bathroom

Your therapists will cover bathroom safety and access with you in detail. They will provide recommendations based on the current layout of your bathroom, for example whether you have a tub or a shower. Sinks should be no higher than 34 inches. Below are some simple suggestions to improve access to your bathroom.

- A toilet height of 22 inches is ideal if transferring from your wheelchair. Consider an elevated toilet seat or placing a bedside commode over your toilet.
- Acquire a hand-held shower hose.
- Apply a non-skid tub mat or strips.
- Lower the mirror and tilt it downwards, if possible.
- Open space below the sink with insulation on the pipes will make it easier to use the sink.
- Install handrails or grab bars to help you transfer to the tub, shower or toilet.

Kitchens

- A lap tray or a rolling cart provides a safe work surface and assists with transporting items.
- Open space below the sink with insulation on the pipes, will make it easier to use. Stove controls should be located on the front.
- Consider a refrigerator with French doors so that you can easily access the freezer section.
- Install Lazy Susans in lower cabinets to allow storage of frequently used items.

Summary

You have been provided with suggestions on how to modify your home to make things easier and safer for you. There are most likely many modifications that you would benefit from. The key is to prioritize which modifications to complete first. Typically, the entrance to your home is the most important, then your bathroom and then your bedroom. You may have other questions concerning changes in your home. If you need more assistance, ask your therapists or social worker. You can also refer to the Americans with Disabilities Act (ADA) Accessibility Guidelines online at Access-board.gov/guidelines-and-standards/buildings-and-sites/about-the-ada-standards/background/adaage

ADA Accessibility Guidelines (2013). Retrieved December 14, 2013 from United States Access Board Web site: www.Access-board.gov/guidelines-and-standards/buildings-and-sites/about-the-ada-standards/background/adaage

RAMP SPECIFICATIONS

Planning the ramp

Before starting construction or purchasing any materials, take note of your needs and what, if any, special features your ramp will need. Accurate scale drawings and plans of ramp projects are necessary when you, your family/friends, or a builder performs a cost analysis and provides a materials.

How wide should it be?

Whether you use crutches, walker, or wheelchair, the ramp needs to be the standard 36 to 48 inch width. Also take into account if the other persons who use mobility devices may also benefit from the ramp and consider their needs when planning.

SECTION V

How much slope should it have?

All buildings built with federal funds and all facilities for persons with disabilities must comply with minimum requirements developed by the federal government and those adapted by it, such as those of the American National Standards Institute. These accessibility standards were developed for the benefit and protection of persons with disabilities and should definitely be considered in residential planning. The guidelines require that a wheelchair ramp have no more than a one-inch rise per one foot of ramp length. The grade is written as a 1:12 slope, but whenever possible, the ramp should have a rise less than 1:12.

The ramp should have no more slope than necessary and if at all possible, no greater than 1:20, or one-inch rise for each 20 inches of length.

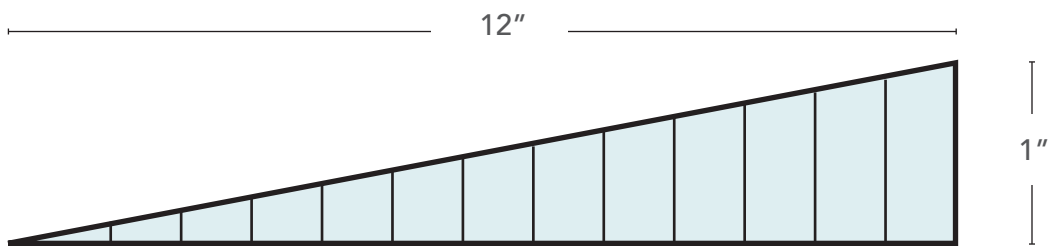

1:12 Grade means that for every one inch of grade you need 12 inches of ramp length.

Where should the ramp be located?

Before deciding where to place your ramp, make a list of all the advantages and disadvantages that various locations have to offer. Consider the following examples as you plan the locations of your ramp:

Advantages:

- Entrance is sheltered by porch, trees, carport, garage, etc.
- Ramp does not block steps and/or existing entrance.
- The height from ground level to entrance level is less than elsewhere.
- A ramp at this location would end near driveway and sidewalk.
- A ramp at this location will not block entrance to crawl space, equipment rooms, storage rooms, outside faucets, or utility meters.

Disadvantages:

- Entrance is not sheltered. Water, ice, snow, etc. could build up at entrance.
- Ramp would block steps and entrance.
- The ground-to-entrance level is at this location is too high.
- Ramp would end in a low area that collects rain and is a long distance from driveway.
- A ramp at this location would be long and costly and would have a rise of more than 1:12.
- Travel on ramp could be dangerous because of the likelihood of ice falling from eaves of house to ramp in winter months.

Terrain

The most important consideration in planning your ramp is the condition of the terrain around the building you to make accessible. Never build a ramp on a down-hill slope so that a person would have a steep climb after entering the ramp. Try to visually survey the terrain and choose the highest point for ramp termination. For example, if you have a distance of 30 inches at the entrance of the building to overcome, you might find a point in the terrain that is near the same height as the entrance. A ramp constructed from that point to the building entrance could be practically level. Make your terrain work for you and not against you.

These are just a few of the factors that need to be considered. Each individual setting will need to be evaluated before choosing a location for the ramp. Try to make a choice that follows as nearly as possible your preferred way of entering and exiting your residence. Don't overlook the possibility of a simple modification to your home in order to gain ramp access. For example, if a porch rail could be cut or removed, or if a window could be removed and a door put in its places, additional access could be gained.

What shape will the ramp need to be?

There is no single, ideal shape for a wheelchair ramp. Instead, numerous factors will dictate the best shape and length for the ramp that will accommodate your own situation and needs. Factors include: the height in inches from the point where it meets the ground to the point where it meets the porch or threshold, the floor plan of the house, the level of the terrain, the shape of the lot, the size of the lot, the location of utilities, the location of the driveway and sidewalks, and many other considerations must also be taken into account.

Will the ramp need landings?

A ramp must have enough level space at the top to allow a person to open doors and turn around as needed while entering or exiting a building. The minimum federal requirement for entrance landings is 5' by 5' (60 inches by 60 inches). This allows enough room to maneuver easily. If there is not an existing porch or similar structure at the entrance level, a landing will need to be constructed. Landings also are needed wherever the ramp changes direction and at thirty foot intervals on long ramps. The bottom of the ramp will need a minimum of 5 feet of level area at the termination point. In addition, ramps might be used to overcome problems caused by grassy, rough, or uneven terrain.

Basic Designs

The following diagrams show examples of four of the most commonly used shapes. They range from the simple straight ramp with one landing to the more complex switch back combination with four landings.

Ramp Designs (top views)

Straight: Two Landings

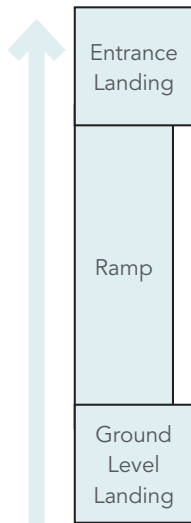

Switchback: Three Landings

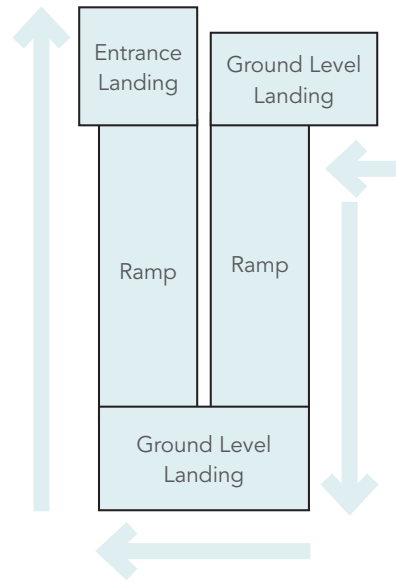

"L" Shape: Three Landings

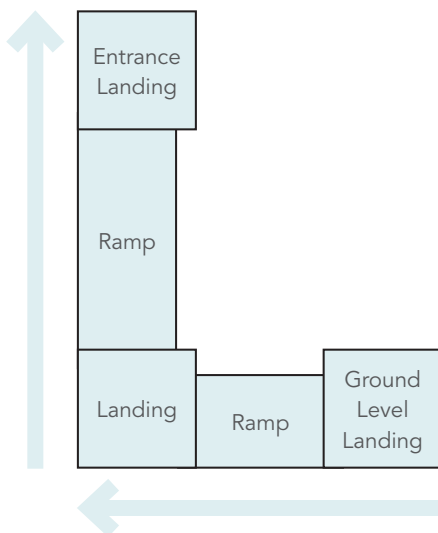

Combination "L" Shape/Switchback: Four Landings

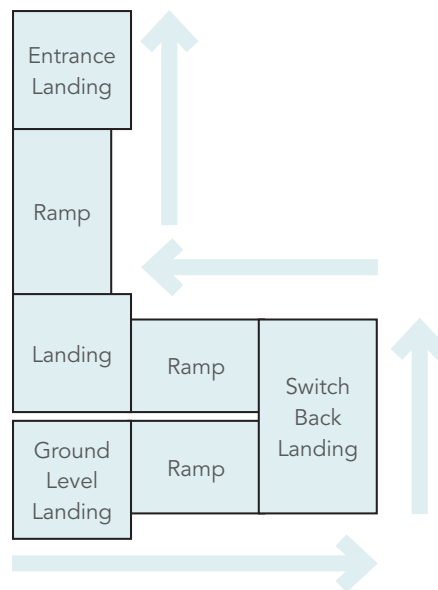

Additional Safety Features

Handrails

A ramp must have sturdy handrails on each side that are large enough for a person to get a secure grip. Handrails should have the following features:

1. If handrails are made of wood, they should be smooth and free of splinters that might stick in hands or arms.
2. If a ramp run has a rise greater than 6" (six inches) or a horizontal projection greater than 72" (seventy-two inches), then it shall have handrails on both sides. Handrails are not required on curb ramps.
3. Handrails should be continuous, if possible. If the rails are not continuous, they must extend 12" (twelve inches) beyond the end of the ramp and must be parallel to the ground or floor surface.
4. The clear space between the handrail and an adjacent wall (if present) should be 1" to 1 1/2" (one foot to one and a half feet)
5. Top of handrail gripping surfaces shall be mounted between 30" and 34" (thirty inches and thirty-four inches) above ramp surfaces. If at any time you wish to use the ramp for walking without the aide of crutches or walker and plan to use the ramp's side rails for hand support, you would need to have the rails at the same height as the hand grips on the assistive device you normally use to walk with.
6. End of handrails shall be either rounded or returned smoothly on floor, wall or post.
7. Handrails shall not rotate within their fittings.

Leveling the Ramp

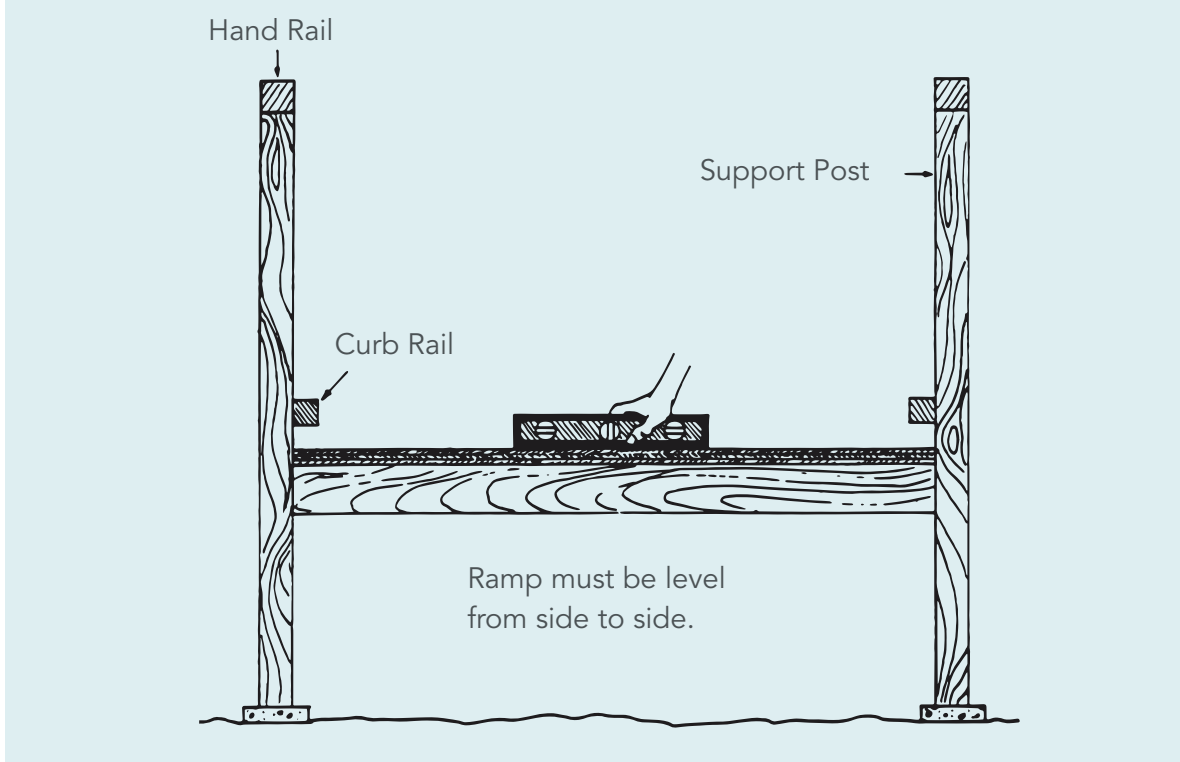

Curb Rails

Curb rails at least 2" (two inches) high must be installed for edge protection around the inner and outer sides of all ramps and landings. These curb rails consist of 2" x 2" strips which are not attached directly to the ramp but must be nailed to the sides of the hand rail supports at a distance of 1 ½" (one and one-half inches) above the surface. A good way of doing this is to position 2" x 4" (two inch by four inch) spacer blocks on the ramp or landing and lay the curb rail on top of these blocks while nailing it to the rail supports. Twelve penny nails should be used so that they will not go through the outside of the hand rail supports. If children use or play on the ramp, additional side protection may be necessary to prevent falls.

Level Surfaces

A ramp must be level from side to side and all landings must be level in all directions to prevent persons from losing their balance or having difficulty controlling their wheelchairs. Irregular surfaces and differences in height from one surface to another should be kept at one-fourth inch (¼") or less. The ramp and its landings must match the threshold height. Make sure the ramp has a good foundation so it will remain level.

SECTION V

Adequate Support

There must be enough support from the ramp to the ground level so that there will be no weak places in the ramp surface. A 2" x 4" (two inch by four inch) upright support every 18 to 24 inches along both sides of the ramp will provide adequate support for the ramp and handrails.

Non-Slip Surface

A good non-slip surface is extremely important. One method is to mix sand with your paint or to sprinkle sand on fresh paint. Textured paint and paints with non-slip material already in them are also available from paint dealers.

Making your ramp safer with curb rails and a non-slip surface.

Use 2 x 2 wood strips for curb rails.

Ramp support posts

Attach curb rail to support posts with 16 penny coated nails

Apply a non-slip ramp surface by sprinkling sand over the surface of the ramp while the paint is still wet. Repeat process for each additional coat of paint.

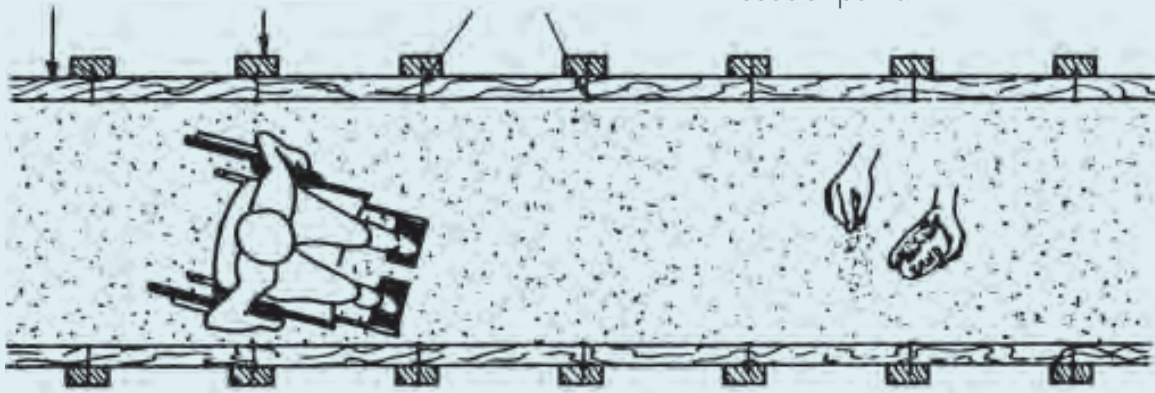

Curb rails help prevent wheelchairs from rolling off edge of ramp.